

# 2020 ISP Appendix 10. Sector Coupling

July 2020

# Important notice

## PURPOSE

This is Appendix 10 to the Final 2020 Integrated System Plan (ISP), available at <https://aemo.com.au/energy-systems/major-publications/integrated-system-plan-isp>.

AEMO publishes this 2020 ISP pursuant to its functions under section 49(2) of the National Electricity Law (which defines AEMO's functions as National Transmission Planner) and its broader functions under the National Electricity Rules to maintain and improve power system security. In addition, AEMO has had regard to the National Electricity Amendment (Integrated System Planning) Rule 2020 which commenced on 1 July 2020 during the development of the 2020 ISP.

## DISCLAIMER

This document or the information in it may be subsequently updated or amended. This document does not constitute legal or business advice, and should not be relied on as a substitute for obtaining detailed advice about the National Electricity Law, the National Electricity Rules, or any other applicable laws, procedures or policies. AEMO has made every effort to ensure the quality of the information in this document but cannot guarantee its accuracy or completeness.

Accordingly, to the maximum extent permitted by law, AEMO and its officers, employees and consultants involved in the preparation of this document:

- make no representation or warranty, express or implied, as to the currency, accuracy, reliability or completeness of the information in this document; and
- are not liable (whether by reason of negligence or otherwise) for any statements or representations in this document, or any omissions from it, or for any use or reliance on the information in it.

## VERSION CONTROL

Version	Release date	Changes
1.0	30/7/2020	Initial release

© 2020 Australian Energy Market Operator Limited. The material in this publication may be used in accordance with the [copyright permissions on AEMO's website](#).

# Contents

<b>Summary</b>	<b>5</b>
<b>A10.1. Introduction</b>	<b>6</b>
<b>A10.2. Hydrogen</b>	<b>7</b>
A10.2.1 Hydrogen has the potential to influence the energy landscape	8
A10.2.2 Strong policy support is needed	10
A10.2.3 Potential roles of hydrogen	12
<b>A10.3. Electric vehicles</b>	<b>17</b>
A10.3.1 Scale of EV consumption across scenarios	17
A10.3.2 Challenges of EV integration	19
A10.3.3 Links to other sectors/technologies	19
<b>A10.4. Gas</b>	<b>21</b>
A10.4.1 Links to other sectors/technologies	21
A10.4.2 Fuel switching	22
A10.4.3 The need for gas system developments	22
<b>A10.5. Energy efficiency</b>	<b>24</b>
A10.5.1 Energy efficiency in the ISP	24
<b>A10.6. Bioenergy</b>	<b>26</b>

## Tables

Table 1	State government hydrogen plans and strategies	9
Table 2	Recent cost estimates for Australian hydrogen production/export	10
Table 3	Summary of potential long term impact of hydrogen flow paths on the NEM and gas system	16

## Figures

Figure 1	Existing and future sector coupling in Australia – Hydrogen flow paths	14
Figure 2	Forecast EV annual energy consumption for the NEM, all scenarios, 2020-50	18
Figure 3	Indicative new gas developments required each year, under Central scenario	23

# 2020 ISP Appendices

## Appendix 1. Stakeholder Engagement

- Stakeholder engagement program and timelines
- Consultation on Draft 2020 ISP

## Appendix 2. Cost Benefit Analysis

- Understanding the cost benefit analysis
- Determining the least-cost development path for each scenario
- Assessing benefits of candidate development paths under each scenario
- Testing the resilience of candidate development paths to events that may occur

## Appendix 3. Network Investments

- Network investments in the optimal development path
- Committed ISP projects
- Actionable ISP projects
- Future ISP projects recommended with preparatory activities
- Other future ISP projects
- Addressing network congestion
- Alternatives considered

## Appendix 4. Energy Outlook

- Future energy supplies for a resilient power system
- Unlocking VRE through REZs
- Managing variable energy supplies through energy storages and firming technologies
- Development outlooks across scenarios
- NEM emission intensity with the least-cost development paths

## Appendix 5. Renewable Energy Zones

- Integrating large volumes of VRE
- REZ framework and design principles
- ISP REZ development
- REZ scorecards

## Appendix 6. Future Power System Operability

- Power system operability models and input
- NEM-wide operability outlook
- Regional risks and insights

## Appendix 7. Future Power System Security

- Renewable Integration Study
- System strength outlook
- Inertia outlook
- REZ opportunities
- South Australia in transition

## Appendix 8. Resilience and Climate Change

- Resilience in the 2020 ISP
- Forecasting climate impacts on energy systems
- Planning for a climate-resilient network
- Next steps

## Appendix 9. ISP Methodology

- Overview of ISP methodology
- Inputs
- Engineering assessment
- Market modelling
- Model outputs

## Appendix 10. Sector Coupling

- Hydrogen
- EVs
- Gas
- Energy efficiency
- Bioenergy

# Summary

This Sector Coupling appendix provides a review of the interactions between sectors including electricity, gas, transport and industry, and how these are modelled in the 2020 ISP. Interactions of technologies such as EVs and energy efficiency are included, and the potential impacts of hydrogen and biofuels are discussed.

## Key insights

- Gas and electricity sectors are already highly coupled. This interaction is explicitly modelled in the ISP since developments in one sector can substantially impact the other
- Interactions between sectors is likely to increase in the future as new technologies develop and are taken up. Understanding the interplay between sectors such as gas, electricity, transport and water is expected to become increasingly important to enable assessment in future ISPs.
- Advancements in hydrogen technology could increase coupling across many sectors. With strong policy support, there is potential for increased uptake of hydrogen production in Australia as an energy carrier. At this stage there is too much uncertainty to measure the possible influences that hydrogen may have on the NEM or other energy systems. This will depend on policy design and the resultant business models, technologies, uses and implementation pathways. Hydrogen may feature more strongly in the 2022 ISP following the development of clearer implementation pathways.
- Fuel switching from gas to electricity is expected to increase demand in the NEM, particularly in space-conditioning as reverse-cycle air conditioners replace gas heating. This growth in consumption is offset by other energy saving activities and is embedded within the energy consumption forecasts of the ISP.
- Energy efficiency and demand response can reduce or defer the need for investment in generation, transmission, and distribution assets.
- Electrification of transport could also change NEM energy consumption and demand, and may be important in the future design of the energy systems. The uptake of electric vehicles is forecast to emerge as a key influence on electricity infrastructure in the next decade; the scale and pace of electrification of transportation is varied as an input across the ISP scenarios.
- There is a continuing need to update regulatory settings and tariff design to efficiently develop the power system to integrate DER. If vehicular charging can be incentivised to better align with times when the power system has abundant local energy supplies, this could reduce the need for investment in the power system infrastructure.
- Gas and electricity are coupled in a range of ways: as a fuel input to GPG to provide firming of the operation of the projected VRE and DER; and as a fuel input or feedstock input to industry that also uses electricity. Investment and development in the gas system is required to secure the operation of GPG and address the likely shortfalls emerging from 2024 in the eastern and southern eastern states.
- Bioenergy has potential to contribute to the gas system or the NEM, as an alternative fuel source for heat and power.

# A10.1. Introduction

This appendix is part of the 2020 ISP, outlining interactions between different sectors, both existing and future. It also highlights technologies that are relevant to the ISP and identifies their potential influence on future ISPs. Sectors and technologies with explicit interactions included in the 2020 ISP modelling (gas, electricity, EVs and energy efficiency) are discussed, along with hydrogen and bioenergy, which may be included in greater detail in the 2022 ISP.

A rapid decline in renewable energy technology costs and increasing targets for emissions reduction across many sectors are driving increased interactions between sectors, commonly referred to as 'sector coupling'. This increase in integration has been recognised internationally, with the European Commission recently releasing its *EU Strategy for Energy System Integration*<sup>1</sup>, calling for 'the coordinated planning and operation of the energy system 'as a whole', across multiple energy carriers, infrastructures, and consumption sectors'.

Interactions between the gas, electricity, transport and building sectors, in particular, are being continuously enhanced and challenged by decarbonisation objectives and technological advancements that are driving electrification of stationary and non-stationary energy sectors, and influencing building design (including consideration of EV charging infrastructure and energy efficiency). Alternative fuels such as biomethane, and energy carriers such as hydrogen have potential to add further to integration across sectors and technologies.

For all technologies, the focus is on their potential impacts on the ISP, and possible challenges to efficient sector integration, to inform the work scope being set for the 2022 ISP.

- **Hydrogen** – since hydrogen remains at the early stages of research and development, this ISP discusses the potential for hydrogen to influence future ISPs.
- **EVs** – while EV charging may not change operational consumption and demand much in the short term, this may change in the future. This section reviews forecast EV energy consumption and demand, and the challenges of EV integration into the NEM.
- **Gas** – as the gas and electricity sectors are highly coupled through GPG, the role of gas in Australia's future energy system is discussed in Section C3.2 of the 2020 ISP, and in further detail in Appendix 6.
- **Energy efficiency** – improvements in the thermal performance of buildings and efficiency of appliances and equipment can deliver significant energy savings critical for achieving decarbonisation policies. This section summarises the assumed impacts of energy efficiency policies on energy consumption and demand used in this ISP.
- **Bioenergy** – biomethane produced from agricultural, industrial or domestic waste is also in the early stages of development. This section discusses the potential use of biomethane as a renewable fuel source which may impact the gas and electricity sectors.

The increase in integration between sectors makes it invaluable for AEMO to have visibility over all coupled technologies, to deliver energy most efficiently to the consumer.

---

<sup>1</sup> European Commission. 'Powering a climate-neutral economy: An EU Strategy for Energy System Integration'. 8 July 2020. COM(2020) 299 final [https://ec.europa.eu/energy/sites/ener/files/energy\\_system\\_integration\\_strategy\\_.pdf](https://ec.europa.eu/energy/sites/ener/files/energy_system_integration_strategy_.pdf).

# A10.2. Hydrogen

## Key hydrogen insights

- While it is early days, interest in hydrogen as an energy source has increased, as evidenced by:
  - Recent upswing in government and private sector plans and pilot projects for hydrogen.
  - The National Hydrogen Strategy presenting Australia’s potential as a large exporter of hydrogen
- Hydrogen plans and strategies have been developed in each jurisdiction, but no policies have been legislated at this stage.
- High cost, lack of infrastructure, and current uncertainty in respect of long-term policy are seen as the main barriers to uptake of hydrogen.
- There is potential for hydrogen to be competitive with diesel for use in long-distance haulage by the early 2030s, and for a green steel industry to develop if global policy shifts to support decarbonisation of the industrial sector.
- However, hydrogen prices need to be much lower than currently projected to compete with gas in many other domestic applications. Shipping costs and low efficiencies are further challenges for development of an Australian export industry.
- With strong policy support, there is potential for significant uptake of hydrogen:
  - Hydrogen export and/or large-scale uptake of domestic/industrial hydrogen could change the location and scale of electrical demand.
  - Hydrogen could be used domestically as an energy carrier, potentially allowing renewable energy to be used to supply low-emissions energy to residences or reduce emissions from hard-to-abate industrial sectors such as steel making.
  - Embedded electrolyzers (utility scale or distributed) could provide benefits to power system security, operability and reliability, depending on their location, infrastructure deployed in the plant, their commercial and technical operations, and supported by market reforms that incentivise and reward appropriately.
  - New gas transmission pipelines/existing distribution pipelines could provide significant energy storage opportunities using hydrogen.

Hydrogen has the potential to play an increasing role in Australia’s energy landscape as it becomes more economically competitive, and the challenges to efficient sector integration are resolved. This 2020 ISP considers some of the potential applications of hydrogen within the Australian energy system. As there has been increasing interest locally and internationally on the possible use of hydrogen as an energy carrier, this ISP highlights the potential for the uptake of hydrogen and outlines the areas for consideration within the 2021 Gas Statement of Opportunities (GSOO) and the 2022 ISP.

An increasing role for hydrogen will not invalidate the actionable ISP projects in the optimal development path. It is important, however, that any future hydrogen strategy is implemented in a manner that is coordinated with other energy policy and system needs. It will also be important to manage additional

electricity or gas network augmentations that may be required to support the evolution of hydrogen under certain pathways.

Hydrogen can be made using several different technologies. These include electrolyzers fed with water and powered by electricity, steam methane reforming (SMR) of natural gas, and gasification of coal. All of these technologies use water. The range of technologies available to developers indicates that uptake of hydrogen has the potential to impact the electricity, gas, coal and water sectors.

## A10.2.1 Hydrogen has the potential to influence the energy landscape

Australia is already a major exporter of energy via liquefied natural gas (LNG) and thermal and metallurgical coal. There is currently much discussion around the potential for Australia to export energy to other countries using hydrogen, either as liquefied hydrogen or via conversion to other compounds such as liquid ammonia. It is also possible that Australian hydrogen production may underpin other export markets, such as “green steel” production.

Hydrogen produced from renewable energy or from fossil fuels with carbon capture and storage (CCS) would enable access to international markets for low/zero emissions energy. The impact of this industry on NEM operations will depend largely on the extent to which hydrogen production facilities, or users of hydrogen fuels, directly connect to the NEM. Where these facilities are grid connected there is potential for the hydrogen sector to shape investments in the NEM, while hydrogen production facilities may also assist in the operation of the power system, through providing seasonal storage and ancillary services to the grid if suitable technology and locational choices are made.

Similarly, hydrogen could be used to help decarbonise the domestic heat, transport and the industrial and commercial sectors in Australia. The scale and rate of take-up of hydrogen-related technologies will affect the emissions profiles for the country in future years and is likely to be closely linked to changes in governmental emissions policies.

Since the 2018 ISP, much research and commentary has been published internationally and locally on hydrogen. Relevant recent work includes:

- **National Hydrogen Roadmap<sup>2</sup>** by CSIRO.
  - The National Hydrogen Roadmap sets out a path for the action and investment plans required to develop the hydrogen economy in Australia. Key findings include hydrogen’s export opportunities, current barriers including lack of infrastructure, and the need for an appropriate policy framework to support the hydrogen industry.
- **National Hydrogen Strategy**, led by Australia’s Chief Scientist Dr Alan Finkel<sup>3</sup>.
  - The National Hydrogen Strategy provides a summary of the state plans, and a medium to long-term vision for the use of hydrogen across the Australian economy. The strategy lays out an adaptive pathway for the hydrogen industry, identifying early ‘no regrets’ actions that can be taken now, and other actions that can be planned for possible future implementation. It also makes a series of recommendations for consideration by all Australian governments.
- **Gas Vision 2050** by Energy Networks Australia and the Australian Pipelines and Gas Association<sup>4</sup>.
  - The Gas Vision 2050 provides an overview of industry-led hydrogen projects which have a total of \$180 million in committed funding. It explores the projects, highlighting key information and innovations.

---

<sup>2</sup> Bruce S, Temminghoff M, Hayward J, Schmidt E, Munnings C, Palfreyman D, Hartley P. 2018. National Hydrogen Roadmap. CSIRO, Australia.

<sup>3</sup> Commonwealth of Australia. 2019. Australia’s National Hydrogen Strategy. COAG Energy Council.

<sup>4</sup> ENA/APGA. 2019. Gas Vision 2050.



- **Australian and Global Hydrogen Demand Growth Scenario Analysis** commissioned by the COAG Energy Council’s National Hydrogen Strategy Taskforce<sup>5</sup>.
- **Future of Hydrogen report**<sup>6</sup> by the IEA.
- **Hydrogen Economy Outlook** by BNEF<sup>7</sup>.

Countries such as Austria, Belgium, Brazil, New Zealand, Norway, France, Japan, Korea, and the United Kingdom have developed hydrogen strategies<sup>8</sup>. The European Commission has recently released a hydrogen strategy for Europe, which aims to reach 40 GW of electrolyzers installed within Europe and 40 GW in neighbouring regions exporting to Europe by 2030<sup>9</sup>. China has hydrogen transport plans for Beijing, Shanghai and Chengdu<sup>10</sup> and is developing Wuhan into the first Chinese Hydrogen city by 2025<sup>11</sup>.

Over the past 12-18 months, each Australian state government and territory has developed a position paper or plan for the advancement of hydrogen-based technology. These are outlined in Table 1 below.

**Table 1 State government hydrogen plans and strategies**

State	Document name	Summary
New South Wales	Net Zero Plan Stage One: 2020-2030	Ten-year plan to reach net-zero emissions, with establishment of hydrogen program a key aspect. Target to blend 10% hydrogen in gas network by 2030.
Queensland	Queensland Hydrogen Industry Strategy 2019-2024	Outlines government plans for investment into hydrogen industry with a focus on supporting innovation, facilitating private investment, effective policy frameworks, building community awareness and facilitating skills development. \$19 million invested into development of hydrogen projects.
South Australia	Hydrogen Action Plan	Sets out the South Australian Government’s actions across five key areas to scale up renewable hydrogen production for export and domestic consumption. Established a \$10 million Renewable Hydrogen Fund to encourage private sector investment.
Tasmania	Renewable Hydrogen Action Plan	Outlines vision and actions to develop a renewable hydrogen industry in Tasmania. Funding package of \$50 million established to encourage investment in the hydrogen industry.
Victoria	Green Hydrogen Discussion Paper	The Victorian Government is currently developing the Green Hydrogen Industry Development Plan. The Victorian Hydrogen Investment Program was established in December 2018 to support green hydrogen technologies.
Western Australia	Western Australian Renewable Hydrogen Strategy	Strategy for the state’s renewable hydrogen future, focusing on four strategic areas: export; remote applications; hydrogen blending in natural gas networks; and transport.

In Australia, there are a series of pilot projects underway, with other large proposals being considered. These range from the production of green hydrogen and ammonia, to those focusing on blending hydrogen into natural gas pipelines and assessing hydrogen fuel cell vehicles. Hydrogen projects in Australia have been funded by both government and private sector investment, with some also receiving international investment.

<sup>5</sup> COAG. 2019. Australian and Global Hydrogen Demand Growth Scenario Analysis.

<sup>6</sup> International Energy Agency. 2019. The Future of Hydrogen.

<sup>7</sup> Bloomberg New Energy Finance. 2020. Hydrogen Economy Outlook.

<sup>8</sup> COAG. Australian and Global Hydrogen Demand Growth Scenario Analysis, 2019, p22, at <https://www2.deloitte.com/content/dam/Deloitte/au/Documents/future-of-cities/deloitte-au-australian-global-hydrogen-demand-growth-scenario-analysis-091219.pdf>.

<sup>9</sup> European Commission. 8 July 2020. ‘A hydrogen strategy for a climate-neutral Europe’. COM(2020) 301 final p.2.

<sup>10</sup> Brasington, Louis, Cleantech, 24 September 2019, “Hydrogen in China”, at <https://www.cleantech.com/hydrogen-in-china/>.

<sup>11</sup> COAG. Australian and Global Hydrogen Demand Growth Scenario Analysis, 2019, p22, at <https://www2.deloitte.com/content/dam/Deloitte/au/Documents/future-of-cities/deloitte-au-australian-global-hydrogen-demand-growth-scenario-analysis-091219.pdf>.

Recent announcements of \$70 million in grants by ARENA and \$300 million in funding by CEFC are also generating increased activity in the sector.

The Australian Government recently released the national Technology Investment Roadmap for consultation<sup>12</sup>. It provides a strategic and system-wide focus for future investments in low-emissions technologies, and considers ways to move new technologies to commercial status as quickly as possible to lead to a sustainable energy future. It considers different options for the future energy mix which includes hydrogen, batteries, carbon capture and storage and natural gas to complement renewable energy. AEMO has undertaken a careful review of the technology roadmap and considers that the ISP is aligned with the roadmap. Future ISPs will continue to carefully look at new technologies and the implementation of the roadmap. This will ensure the optimal development path of future ISPs considers future technologies and sectors that increasingly couple with the power system appropriately.

## A10.2.2 Strong policy support is needed

Although significant effort has been put into development of hydrogen plans and strategies across the various jurisdictions in Australia, no policies have been legislated at this stage. High cost, lack of infrastructure, and uncertainty in respect of long-term policy, are seen as the main barriers to uptake of hydrogen.

- There is potential for hydrogen to be competitive with diesel for use in long-distance haulage by the early 2030s, and for a green steel industry to develop if global policy shifts to support decarbonisation of the industrial sector.
- However, hydrogen prices need to be much lower than currently projected to compete with gas in many other domestic applications. Shipping costs and low efficiencies are further challenges for development of an Australian export industry.

Cost estimates for a range of hydrogen applications in Australia under current regulatory conditions from recent studies are summarised in Table 2. Further detail is provided in the following sections.

**Table 2 Recent cost estimates for Australian hydrogen production/export**

Market	Notes	Price 2030 (A\$/GJ) <sup>A</sup>	Price 2050 (A\$/GJ) <sup>A</sup>	Summary
Green hydrogen for Export	BNEF: Assumes transport via ammonia to Japan <sup>B</sup> .	-	33	While not comparable to local production cost in Japan of A\$19/GJ in 2050 (due to high shipping costs at 70% of total cost), land and energy constraints require Japan to import energy. Australia will need to compete with other countries to supply this market.
Green hydrogen to large industry	BNEF: includes 50 km pipeline transport <sup>B</sup> .	17.4	10	Not comparable to recent and projected natural gas prices until around 2050 without carbon price.
Hydrogen from brown coal with CCS to industry	CSIRO: Assumed successful demonstration gasification and CCS at scale and export market agreements in place <sup>C</sup> .	15-19	-	Requires scale of export market but does not include transport costs. Not comparable to recent and projected natural gas prices.

A. Prices quoted in A\$2019, cost conversions assume exchange rate of 0.6 US\$/A\$, and Higher Heating Value of hydrogen of 141.7 MJ/kg.

B. BNEF. Hydrogen Economy Outlook, 2020.

C. CSIRO. National Hydrogen Roadmap. 2018.

<sup>12</sup> Commonwealth of Australia. 2020. Technology Investment Roadmap Discussion Paper.

## Residential/industrial use

The recent BNEF study<sup>13</sup> forecasts that by 2030 hydrogen costs delivered to large industrial users in Australia could be US\$1.48/kg, dropping to US\$0.84/kg by 2050. This is equivalent to A\$17.4/GJ in 2030 and A\$9.9/GJ in 2050 (in \$2019 and assuming an exchange rate of 0.6 US\$/A\$), which indicates that without significant subsidies, hydrogen will not reach parity with recent and projected natural gas prices until close to mid-century.

## Export

Export from Australia to other countries is forecast to add up to an additional US\$3/kg for shipping via ammonia due to the significant energy and processing facilities required for conversion and transport, making export costs two to three times higher than for domestic usage. Recent reports by The Grattan Institute<sup>14</sup> and Bloomberg New Energy Finance (BNEF)<sup>13</sup> have highlighted the economic challenges for this route due to high transport costs. BNEF estimates that by 2050 the cost of hydrogen exported from Australia and delivered to Japan will be US\$2.8/kg (equivalent to A\$33/GJ), compared to the cost of local production in Japan of US\$1.6/kg (equivalent to A\$19/GJ).

## Transport

As renewable hydrogen becomes more competitive with fossil-fuel based production, there is an opportunity for decarbonisation of the transport sector. The CSIRO National Hydrogen Roadmap notes that fuel cell electric vehicles (FCEV) may have greater advantages over battery electric vehicles (BEV) for longer distance travel (400-600km without refuelling)<sup>15</sup>. However Bloomberg suggests that the strongest case for hydrogen use in transport will be for the heavy trucking industry, with fuel cell powered trucks forecast to compete with diesel internal combustion engines (ICE) by 2031-34<sup>13</sup>. The Hydrogen Council forecasts that FCEV trucking may become competitive with conventional technology before 2030 if the hydrogen cost at the pump was between US\$4-\$5 per/kg and depending on the cost of diesel<sup>16</sup>.

The main barriers to hydrogen uptake in long distance trucking are the current capital cost of FCEV and lack of infrastructure<sup>15</sup>. Road freight is the main mode of transport for goods in Australia. Over 95% of road freight is carried in heavy vehicles<sup>17</sup>. From a NEM perspective, an increase in FCEVs would require refuelling stations to be established across major freight lines. These would be likely to utilise existing truck stops and service centres but may require new NEM infrastructure or upgrades.

## Green steel

Recent reports<sup>14,18</sup> highlight the potential for green steel production in Australia due to abundant renewable resources and the increased demand for low emissions industrial commodities worldwide. Conventional steel making uses a blast furnace to reduce iron ore to pig iron, which is then converted to steel in a basic oxygen furnace. Coal is used in the blast furnace, both to provide heat energy and also in the chemical reduction of iron oxides to form pig iron. This process produces CO<sub>2</sub>, which contributes to greenhouse gas emissions.

'Green steel' can be made via a direct reduction process. This uses hydrogen (made from renewable energy) as the heat source and reducing agent to produce the pig iron, which is then fed to an electric arc furnace to produce crude steel. The by-product of the iron reduction process using hydrogen is water, rather than carbon dioxide. If renewable electricity was used as the energy source for the electric arc furnace and

---

<sup>13</sup> BNEF. Hydrogen Economy Outlook, 2020.

<sup>14</sup> Grattan Institute. 2020. Start with steel: A practical plan to support carbon workers and cut emissions, at <https://grattan.edu.au/report/start-with-steel/>.

<sup>15</sup> CSIRO. National Hydrogen Roadmap. 2018, pxviii.

<sup>16</sup> Hydrogen Council, Path to hydrogen competitiveness: A cost perspective, 20 January 2020, p 38 <https://hydrogencouncil.com/wp-content/uploads/2020/01/Path-to-Hydrogen-Competitiveness-Full-Study-1.pdf>.

<sup>17</sup> BITRE, Hydrogen as a Transport Fuel, 2019, p20 [http://www.coagenergycouncil.gov.au/sites/prod.energycouncil/files/publications/documents/nhs-hydrogen-as-transport-fuel-report-2019\\_0.pdf](http://www.coagenergycouncil.gov.au/sites/prod.energycouncil/files/publications/documents/nhs-hydrogen-as-transport-fuel-report-2019_0.pdf).

<sup>18</sup> Energy Transition Hub, 2019, From mining to making – Australia's future in zero-emissions metal [https://www.energy-transition-hub.org/files/resource/attachment/zero\\_emissions\\_metals.pdf](https://www.energy-transition-hub.org/files/resource/attachment/zero_emissions_metals.pdf).

auxiliaries, there would be the potential to produce low-emissions green steel. The potential challenges here include resolution of technical requirements; Australia's distance from metal consumers; and competition in low-emissions metals from other countries with cheap renewable energy<sup>19</sup>.

A substantial shift in global carbon policy would be required to make green steel a viable commodity. Current estimates show that a hydrogen price of US\$1-\$3/ kg hydrogen would mean that green steel making costs are 25%-60% higher than fossil fuel-based production<sup>20</sup>. If there was a coordinated global push to decarbonise industrial areas such as steel production, and policies were introduced to support this, significant production of green steel in Australia could occur.

An expansion in the green steel making industry has potential impacts for the NEM. Production may be focused in current mining intensive areas such as central Queensland, the Hunter, Pilbara, Whyalla, Portland where there is access to ports and to high-voltage electricity network connections. From a NEM perspective, this would require consideration of infrastructure and network development requirements for importing electricity from the grid and also exporting power when variable renewable energy is in surplus<sup>20</sup>.

## A10.2.3 Potential roles of hydrogen

### Sector coupling

To estimate the potential roles and opportunities that may arise from hydrogen, it is necessary to consider the possible pathways via which hydrogen may be deployed across Australia's energy systems. The analysis must include not only the electricity sector, but look to its application in the sectors of gas, transport, industry and infrastructure.

Figure 1 shows a schematic of the existing Australian east coast electricity and gas systems, overlaid by potential new hydrogen generation, transmission and distribution assets. Highlighted lines show possible flow paths utilising hydrogen for transport of energy. Existing sector coupling between electricity, gas (residential and industrial use), and transport (EVs) sectors, is already included in ISP modelling, along with interactions from energy efficiency and DER technologies. Examples of this coupling include power generation from gas turbines (GPG) and the competition between gas and electricity to supply demand for heating and industrial use. The addition of hydrogen to the landscape shows the potential increase in sector coupling by adding a third choice of energy carrier between the generation sources and the end users of energy. Coupling of the transport sector with electricity (and to some extent gas via compressed natural gas) is already beginning to emerge, and is expected to increase significantly as the uptake of electric vehicles (EVs) grows.

### Flow paths

The hydrogen production technology and level of centralisation/decentralisation and geographic location will notably change the impact on the NEM, as illustrated in Figure 1. Three potential flow paths for hydrogen production are:

- **Flow path A** shows hydrogen being produced by either utility scale electrolyzers positioned close to a renewable energy zone (REZ), or from fossil fuels using steam methane reforming (SMR) of gas or gasification of coal. Hydrogen is then transmitted via a new pipeline system to the distribution system, or directly to export facilities. New hydrogen transmission pipelines may be required, allowing the sector to largely bypass existing gas and electricity transmission infrastructure. The distribution of the hydrogen could change demand patterns for gas and/or electricity depending on how it is used.
- **Flow path B** has utility scale hydrogen production located on the electrical transmission system close the point of consumption (ports/industry/cities). If hydrogen is produced by electrolyzers then increased utilisation of electricity infrastructure may lead to a need for augmentation of either generation facilities or

<sup>19</sup> Energy Transition Hub, 2019, From mining to making – Australia's future in zero-emissions metal [https://www.energy-transition-hub.org/files/resource/attachment/zero\\_emissions\\_metals.pdf](https://www.energy-transition-hub.org/files/resource/attachment/zero_emissions_metals.pdf).

<sup>20</sup> Grattan Institute. 2020. Start with steel: A practical plan to support carbon workers and cut emissions, at <https://grattan.edu.au/report/start-with-steel/>

electricity transmission lines. If hydrogen is produced by SMR of gas, the gas network may require augmentation to enable delivery, unless hydrogen is a pure substitute for gas demand. The scale of either gas or electricity augmentation would depend on the specific location and gas/electricity infrastructure available within proximity of the hydrogen production facility.

- **Flow path C** illustrates the use of smaller scale distributed electrolyzers at multiple locations within electrical distribution networks, producing hydrogen which is blended into the existing gas distribution network, or stored locally if pure hydrogen was required, for example for transport. These could be positioned to allow intermittent conversion of excess electrical power from distributed PV into hydrogen, enabling storage of excess energy in the gas distribution system (as line pack) or in dedicated storage facilities.

For both paths A and B, distribution to export and transport users would require new dedicated hydrogen pipelines, assuming that pure hydrogen is required, (although hydrogen/methane blends may be viable for transport applications). However, distribution to industry/residential could occur via blending into the natural gas network or via dedicated hydrogen trucking using bulk tankers (industry) or cylinders (residential) in an extreme case. Blending into gas distribution pipelines is currently considered feasible up to 10%vol hydrogen and may eventually be feasible up to 100% depending on materials of construction and compatibility of end use equipment and appliances. Both paths A and B allow the option of provision of low-emission heat via hydrogen (either from renewables or fossil fuels with carbon capture and storage) to residential/industrial consumers via the gas distribution network, avoiding additional congestion of electrical distribution networks.

Flow path C could be used either stand-alone, or in combination with either path A or B, and the benefits of connecting electrolyzers to the grid are outlined below. A combined option which incorporates both utility scale and distributed electrolyzers could have the optimum benefits – further work is planned for the 2022 ISP to investigate the potential impacts of these paths on the NEM and gas systems.

Figure 1 Existing and future sector coupling in Australia – Hydrogen flow paths

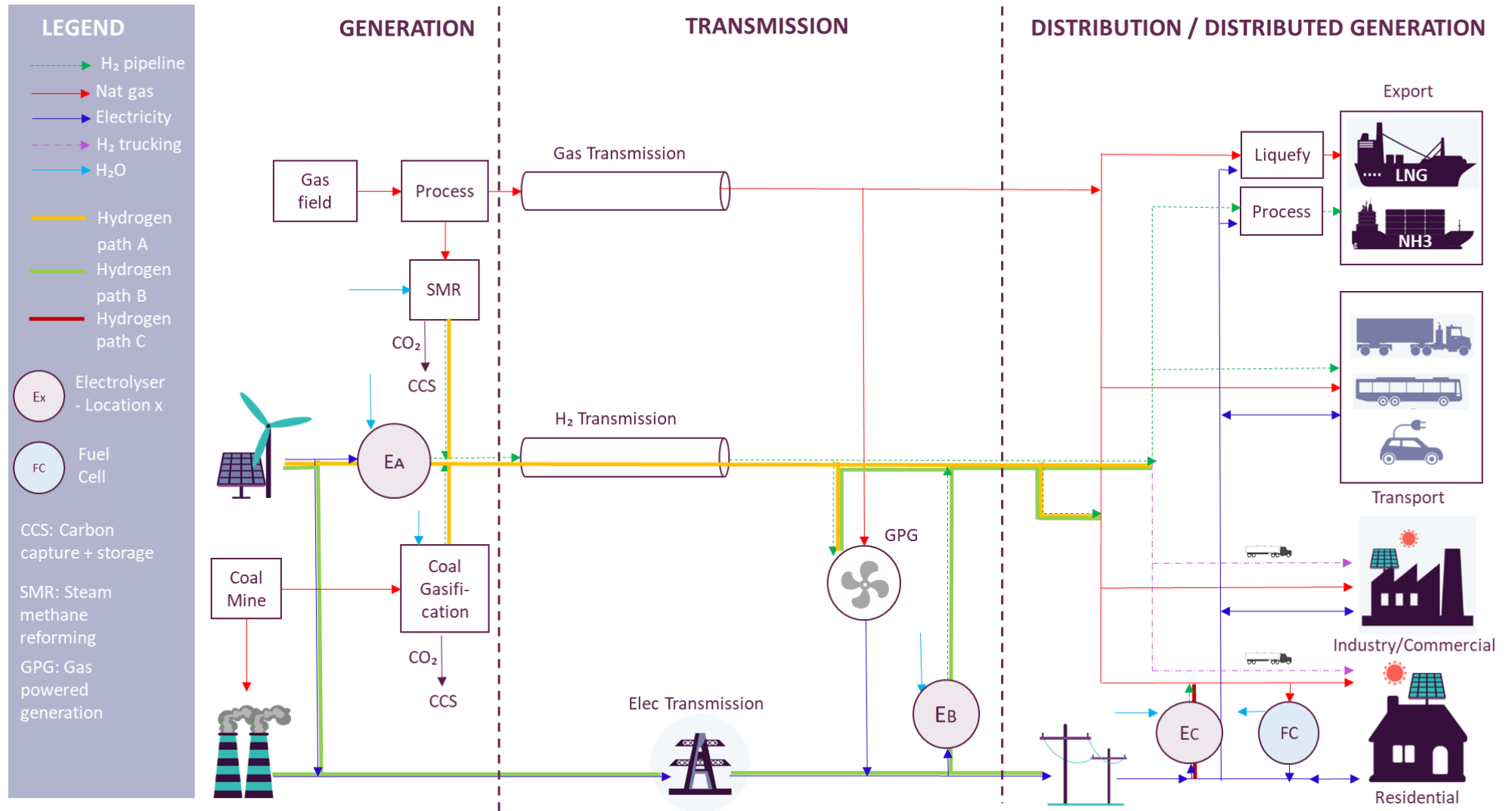

## **NEM reliability and security**

Flow paths B and C that involve connection of electrolyzers to the transmission or distribution networks could provide benefits to the electricity sector to varying degrees. Well placed electrolyzers matched with suitable energy supplies could reduce congestion on the network, or, conversely, if not well matched, could create congestion. Other potential opportunities include:

- Electrolyzers may be designed to operate as a more flexible, responsive demand that can be used for the management of load profiles, via load shifting and reduce curtailed energy. An electrolyser may:
  - Consume more electricity during periods where supply is plentiful, for example during daytime when solar energy is abundant, potentially increasing minimum demand periods.
  - Consume less electricity during periods where supply is tight, for example leading up to and during the evening peak, when solar energy is reducing and other electricity generation needs to ramp up to compensate.
- Electrolyzers connected to the transmission system may be designed to provide frequency control services. Their technical characteristics could allow them to offer emerging services, such as Fast Frequency Response (FFR).
- Electrolyzers connected through particular inverter designs could also be designed to offer voltage support services to the transmission or distribution networks.

Each of these potential opportunities for electrolyzers need to be tested, both technically (to ensure the capability exists) and also commercially (to ensure that there is a suitable payment mechanism to reward the service).

## **Gas system security and operability**

Blending of hydrogen into the natural gas network would create challenges also, including:

- Suitable pipeline materials, as although polyethylene distribution pipelines have been proven to accommodate up to 10% hydrogen blend with natural gas, higher hydrogen percentages are currently untested.
- Management of supply disruptions due to variable operations of electrolyzers, especially if providing dispatchable services into the NEM as noted above.
- Gas quality excursions due to variable blending rates of hydrogen and/or inadequate mixing of hydrogen before reaching the end user.
- Metering issues due to variable gas heating value.
- Forecasting of annual and peak day gas demand will become more complex due to the variability of hydrogen blending rates into the distribution network.

Regulatory changes would need to be progressed to enable the blending of hydrogen into natural gas pipelines. Wholesale and retail gas market design may need to be amended, and existing gas supply agreements may also require amendments.

## **Hydrogen storage**

All flow paths could provide further benefits if stored hydrogen (either from gas transmission pipelines or from gas/hydrogen distribution pipelines) is used as fuel for generation, where market arrangements permit. This could be done by supplying gas turbine generators suited for hydrogen, or within the distribution system via distributed fuel cells. Using this technology, hydrogen could provide a fuel source for dispatchable generation over short timeframes (ie. meeting the evening ramping and peak demand requirements), or over longer timeframes (overnight or during wind droughts).

## Potential outcomes from stronger uptake of hydrogen

Assuming policy support breaks down barriers to commercial viability to enable the strong uptake of hydrogen, the potential outcomes for electricity and gas systems can be summarised as in the table below.

**Table 3 Summary of potential long term impact of hydrogen flow paths on the NEM and gas system**

Flow path	Description	Impact on NEM grid/markets	Impact on NEM reliability/security/operability	Overall impact on NEM	Overall impact on Gas system
<b>A</b>	Utility scale electrolysers near REZs  hydrogen transmission pipelines  Blending into national gas distribution lines or localised trucking	No direct impact if solely for export  If supplying domestic markets, reduced load on electricity transmission	If supplying domestic markets, provides significant storage and dispatchable power via GPGs  Enhanced security and operability if connected to NEM	Low (export only)  Med-High (domestic)	May impact gas demand  Conversion of gas distribution networks to 100% hydrogen required
<b>B</b>	Utility scale electrolysers near consumers  Elec Transmission (and minor new hydrogen transmission)  Blending into national gas distribution lines or localised trucking	NEM augmentations needed due to increased electricity demand  May change bulk power flows within NEM depending on export locations	Provides some storage (via short new hydrogen transmission) and dispatchable power via GPGs  Large NEM security and operability benefits via load shifting and demand response	High	May impact gas demand  Conversion of gas distribution networks to 100% hydrogen required
<b>C</b>	Distributed small scale electrolysers within cities  Via existing transmission or flow paths A or B	NEM augmentations may be needed (if electricity demand increased or combined with path B)	Provides some storage and dispatchable power via fuel cells  Large NEM benefits via load shifting and demand response  Also benefits operability of distribution networks	High	Conversion of gas distribution networks to increased hydrogen required



# A10.3. Electric vehicles

## Key electric vehicles insights

- EV development has been slow in Australia to date, relative to other countries, especially those with clear policies, and is forecast to remain muted during the 20's unless policy changes and market reforms are realised. Future EV growth may have positive or negative implications for the electricity system, particularly for passenger, commercial and light industrial vehicles.
- Vehicle to Home/Vehicle to Grid Technology could reduce future demand for utility and distributed batteries.
- If vehicular charging can be incentivised to better align with times when the power system has abundant local energy supplies, this could reduce the need for investment in the power system infrastructure.
- An emerging challenge with strong EV integration will be the coordination / facilitation of two-way charging / discharging, visibility and operational forecasting for system operations (impacting the transmission system as well as the distribution systems), meeting user expectations while managing distribution network peak load challenges, and minimising infrastructure upgrade costs.
- Smart EV chargers are a necessary enabler for efficient coupling between the energy, transport and infrastructure sectors.
- AEMO is collaborating with industry, government and regulatory bodies on the opportunities and challenges presented by EVs, via the Distributed Energy Integration Program.

## A10.3.1 Scale of EV consumption across scenarios

EV adoption is anticipated to have only a small impact on electricity consumption in the short term, with current forecasts indicating the impact of EVs is expected to be noticed most from the 2030s onwards. The degree of policy-driven transport sector decarbonisation is a key driver for the scale of electrification, and alternative outlooks exist with higher electrical load with higher transport emissions reduction, as demonstrated in the figure. Lower estimates may also eventuate depending on the potential competition provided by hydrogen fuel cell vehicles with EVs.

Figure 2 below demonstrates the electricity consumption forecast across the ISP scenarios. These forecasts are consistent with those developed for the 2019 ESOO for the NEM, developed with the assistance of CSIRO and Energeia. More detail on the drivers, drivers for uptake and electricity consumption trajectories are available in the consultant's published reports<sup>21</sup>.

<sup>21</sup> CSIRO, 2019 Projections for small-scale embedded technologies report, at [https://www.aemo.com.au/-/media/Files/Electricity/NEM/Planning\\_and\\_Forecasting/Inputs-Assumptions-Methodologies/2019/2019-Projections-for-Small-Scale-Embedded-Technologies-Report-by-CSIRO.pdf](https://www.aemo.com.au/-/media/Files/Electricity/NEM/Planning_and_Forecasting/Inputs-Assumptions-Methodologies/2019/2019-Projections-for-Small-Scale-Embedded-Technologies-Report-by-CSIRO.pdf). Energeia, Distributed Energy Resources and Electric Vehicle Forecasts, at [https://www.aemo.com.au/-/media/Files/Electricity/NEM/Planning\\_and\\_Forecasting/Inputs-Assumptions-Methodologies/2019/Distributed-Energy-Resources-and-Electric-Vehicle-Forecasts---Report-by-Energeia.pdf](https://www.aemo.com.au/-/media/Files/Electricity/NEM/Planning_and_Forecasting/Inputs-Assumptions-Methodologies/2019/Distributed-Energy-Resources-and-Electric-Vehicle-Forecasts---Report-by-Energeia.pdf).

**Figure 2 Forecast EV annual energy consumption for the NEM, all scenarios, 2020-50**

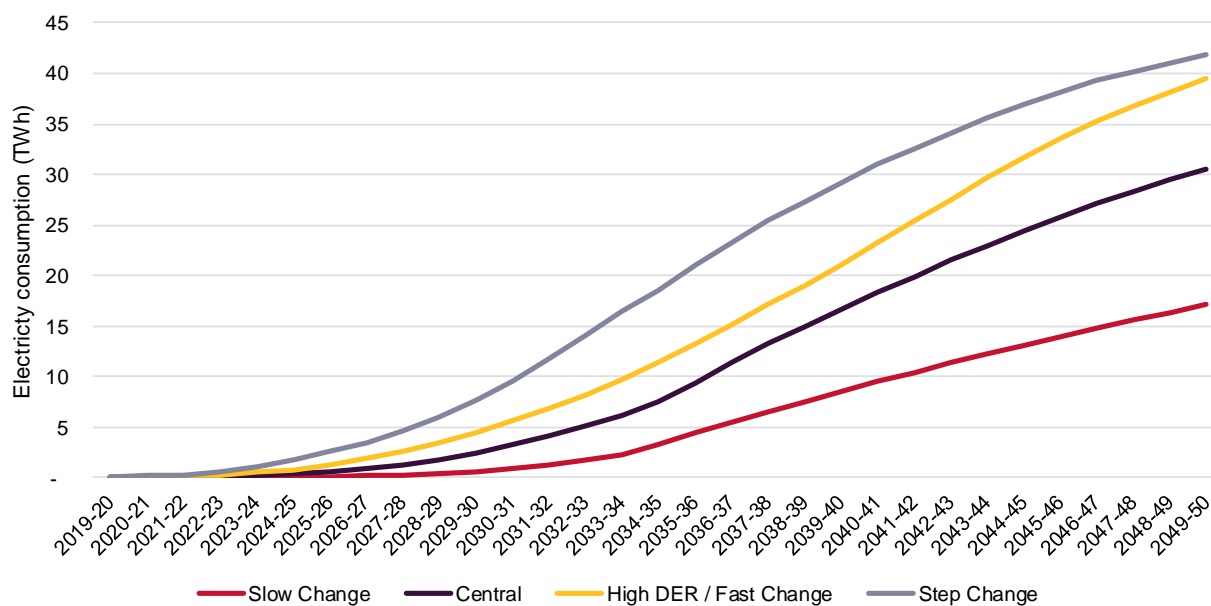

Traditional internal combustion engine (ICE) vehicles have long driving ranges relative to normal daily drive distances, leading to irregular fuel re-fills (for example on a weekly or fortnightly basis). While EVs also have a driving range that exceeds most daily driving needs, the convenience available to households of daily charging to top up batteries is expected to lead to a very different fuelling behaviour than with ICE vehicles.

The charging behaviours of consumers – through at-home, en-route, or at-destination charging facilities – will influence whether daytime charging habits help absorb solar-generated energy, or night-time charging habits result in a need for alternative energy sources and/or storages.

Charging “when convenient” will amplify morning and evening peaks, however a shift towards alternative charging behaviours can help minimise the impact of EVs, and in some circumstances assist in the management of the power system through vehicle-to-home or vehicle-to-grid discharging patterns. Achieving this shift to daytime charging will require technological and commercial developments to encourage drivers to be mindful of their impact on the power system when charging. These challenges are expanded on in the following section.

For the ISP, a gradual shift from convenience-based charging (evening and overnight charging), to alternative charging patterns that distribute vehicle charging and reduce the EV contribution to peak demand is applied, at various speeds across the scenarios. The Slow Change scenario, with the least EV uptake, likewise has the slowest and least amount of charging outside of times of pure ‘convenience’. At the other end of the spectrum, the Step Change scenario, with the greatest degree of transport electrification assumes much greater awareness of the benefits to decarbonisation and energy system costs by consumers, shifting more consumption towards alternative charging profiles, while retaining a relatively high convenience charging rate (given that EVs primary purpose is to be available for transportation needs).

Further detail on the assumed charging behaviours is available in the 2019 ESOO and Consultant reports<sup>22</sup>.

<sup>22</sup> CSIRO, 2019 Projections for small-scale embedded technologies report, at [https://www.aemo.com.au/-/media/Files/Electricity/NEM/Planning\\_and\\_Forecasting/Inputs-Assumptions-Methodologies/2019/2019-Projections-for-Small-Scale-Embedded-Technologies-Report-by-CSIRO.pdf](https://www.aemo.com.au/-/media/Files/Electricity/NEM/Planning_and_Forecasting/Inputs-Assumptions-Methodologies/2019/2019-Projections-for-Small-Scale-Embedded-Technologies-Report-by-CSIRO.pdf). Energeia, Distributed Energy Resources and Electric Vehicle Forecasts, at [https://www.aemo.com.au/-/media/Files/Electricity/NEM/Planning\\_and\\_Forecasting/Inputs-Assumptions-Methodologies/2019/Distributed-Energy-Resources-and-Electric-Vehicle-Forecasts---Report-by-Energeia.pdf](https://www.aemo.com.au/-/media/Files/Electricity/NEM/Planning_and_Forecasting/Inputs-Assumptions-Methodologies/2019/Distributed-Energy-Resources-and-Electric-Vehicle-Forecasts---Report-by-Energeia.pdf).

## A10.3.2 Challenges of EV integration

EVs represent a nexus of the transport, energy and infrastructure sectors, requiring co-optimisation to achieve efficient coupling. As Figure 2 in the previous section shows, EVs have the potential to significantly impact grid requirements in the future, particularly if charging patterns overlap with traditional peak demands. An unmanaged transition to electrified transportation could prove challenging and costly (for example, requiring augmentation of the electricity distribution network to enable simultaneous charging of large numbers of EVs in residences). A purely least-cost solution from an energy sector perspective may not provide the degree of flexibility that some consumers will want (for example, strictly limiting EV charging to off-peak periods could impact on urgent mobility needs of some consumers).

To facilitate this co-optimisation, EV rollout must be supported by appropriate market frameworks and regulation (both in electricity and transport sectors) that can both meet consumer demand (for simple and efficient powering of their vehicles) and support the power system of the future, by utilising smart technology and data-driven decision making to optimise for overall consumer benefit.

Preparing now for the wide-spread adoption of electrified transportation will assist with efficient integration of EVs into existing and future markets and networks. As part of AEMO's DER Program, AEMO is collaborating with industry, government and regulatory bodies via the Distributed Energy Integration Program (DEIP) EV Grid Integration Working Group, with efforts currently focussing on data availability, standards, tariffs and incentives. By leveraging experience from international jurisdictions further along the EV adoption curve, this work seeks to capture value already demonstrated by EVs in overseas electricity markets and systems, while recognising that data relevant to Australia is needed to facilitate modelling and consumer research.

From a technology perspective, smart EV chargers are a necessary enabler for efficient coupling between the energy, transport and infrastructure sectors. Smart chargers with a minimum level of capability with regards to features, performance and interoperability will allow EV grid integration opportunities to be maximised and challenges mitigated. By placing these intelligent devices at edge-of-grid, it will be possible to co-optimize the timing of vehicle charging to both meet the mobility needs of consumers and the security and reliability needs of the power system.

For example, by incentivising or coordinating charging activity at times of energy supply surplus (for example during abundant solar generation periods during the middle of the day) consumers can take advantage of low energy prices while mitigating the need for network augmentation to cater for charging at times of peak demand later in the day. By utilising information on consumer behaviour, charging preferences and driving patterns, data-driven decisions can be made to ensure charging infrastructure is available in the locations where EVs are parked during the day.

## A10.3.3 Links to other sectors/technologies

The EV sector is an emerging part of the transportation sector, but uptake of EVs will also be influenced by the developments in other sectors:

- **Batteries:**
  - Degraded EV batteries that are no longer suitable for use in EVs may be reused for grid scale or behind the meter applications.
  - Vehicle to Home/Vehicle to Grid Technology (allowing use of the car battery to power the home or export to the grid) could reduce demand for home batteries in the future. AEMO's current Step Change scenario includes the emergence of vehicle-to-home discharging, reducing the grid requirements.

- **Infrastructure and buildings:**
  - The scope and scale of infrastructure required to support uptake of EVs will vary greatly depending on the time, location and method of charging adopted. At-home charging could place significant load on local distribution networks, requiring costly upgrades. Alternatively, distributed charging hubs within cities and on major transit routes will require considerable investment and coordination of new infrastructure, including electrical transmission and/or distribution assets, and building design.
- **Artificial intelligence and machine learning technology:**
  - Autonomous rideshare vehicles have the potential to reduce private ownership of vehicles in the future. This is considered in CSIRO's 2019 EV forecasts<sup>23</sup>, and included in the forecasts that were used in the 2020 ISP.
- **Generation** – if appropriate market reforms are in place:
  - EV charging may be able to be used to help flatten large daily fluctuations in demand and supply by charging during times of high renewable generation and low delivered demand.
  - If well designed and incentivised, wider spread adoption of Vehicle to Grid may potentially be able to reduce the need for grid scale batteries. If designed appropriately, this might also potentially provide additional sources of ancillary grid stabilisation services such as FCAS.

---

<sup>23</sup> See Section 4.9 of CSIRO: Projections for small-scale embedded technologies 2019 and 2020, at [https://aemo.com.au/-/media/files/electricity/nem/planning\\_and\\_forecasting/inputs-assumptions-methodologies/2019/2019-projections-for-small-scale-embedded-technologies-report-by-csiro.pdf?la=en&hash=0C29A4F28145667AF5C9B48791F11CF6](https://aemo.com.au/-/media/files/electricity/nem/planning_and_forecasting/inputs-assumptions-methodologies/2019/2019-projections-for-small-scale-embedded-technologies-report-by-csiro.pdf?la=en&hash=0C29A4F28145667AF5C9B48791F11CF6) and [https://aemo.com.au/-/media/files/electricity/nem/planning\\_and\\_forecasting/inputs-assumptions-methodologies/2020/csiro-der-forecast-report.pdf](https://aemo.com.au/-/media/files/electricity/nem/planning_and_forecasting/inputs-assumptions-methodologies/2020/csiro-der-forecast-report.pdf).

# A10.4. Gas

## Key gas sector insights

- Gas and electricity sectors are highly coupled via gas-powered generators (GPG) and major industry's energy usage. Investment decisions in the two sectors are inter-related.
- Investment and development in gas production and networks is required to combat shortfalls in gas supplies and delivery risks forecast in the 2020 GSOO<sup>24</sup>, emerging from 2023-24 in the eastern and south-eastern states.

## A10.4.1 Links to other sectors/technologies

Currently, the gas and electricity sectors are highly coupled, with GPG providing a key source of energy and peak demand support, and gas providing an alternative to electricity in heating and cooking appliances as well as industrial use. As such, developments in the gas sector may influence the future needs of the power system, and vice versa. For this reason, AEMO takes a proactive role in forecasting the co-optimised development of infrastructure in both the gas and electricity systems within the ISP, provides projections of supply adequacy in the ESOO and GSOO, and considers the opportunities for energy efficiency and fuel-switching by consumers in forecasting energy consumption and peak demands.

Linkages and coupling between the gas sector and other sectors include:

- **Residential and commercial consumers** through:
  - **Fuel switching for heating (from gas to electricity)** – particularly as reverse-cycle air conditioners increase in penetration and consumers use these devices rather than gas heating.
  - **Increased uptake of EVs** – similar to the above, an increased uptake of EVs would increase the electricity demand on the NEM and may influence GPG operation, particularly if EV charging increases consumption during evening peaks – a traditional time when GPG are operating. The scale of impact will be influenced by the availability of alternative lower cost energy supplies, such as coal or renewable energy and the proportion of EVs charged for convenience for the owner but sub-optimally for the power system.
- **Industrial sector:**
  - Industrial users continue to report vulnerability to the cost of energy resources. Any significant change in industrial activity would materially impact both gas and electricity demands.
  - Improved energy efficiencies in industrial processes could potentially reduce both electricity and gas demands.

<sup>24</sup> At [https://aemo.com.au/-/media/files/gas/national\\_planning\\_and\\_forecasting/gsoo/2020/2020-gas-statement-of-opportunities.pdf?la=en](https://aemo.com.au/-/media/files/gas/national_planning_and_forecasting/gsoo/2020/2020-gas-statement-of-opportunities.pdf?la=en).

- **Hydrogen:** development in the hydrogen industry would potentially impact both gas and electric demands (as previously mentioned in section A10.2).

More information on the consumption forecasts of gas consumers, and the peak gas demands (in winter months), is available in the 2020 GSOO<sup>25</sup>. Appendix 6 of this 2020 ISP provides detail on the expected energy outlook and operability influences on the operation of GPG forecast in the 2020 ISP.

## A10.4.2 Fuel switching

AEMO incorporates fuel-switching of consumers away from gas appliances towards electrical devices within the energy efficiency forecasts, as the effects of both demand drivers are intertwined. The ISP assumes a shift from gas to electricity for space conditioning.

- In the residential sector, for example, reverse-cycle air-conditioning is expected to reduce gas demand that could have arisen due to gas heating.
- In the commercial sector, the energy efficiency forecasts adopt fuel mix assumptions from building code regulation impact statements. For energy efficiency policies focused on decarbonisation, the gas to electricity switch is expected to be more prevalent once the average emission intensity of the electricity sector falls below that of the gas sector.

Building energy performance requirements contained within the National Construction Code is also forecast to result in a modest increase in gas water heating in Victoria, additional to the effects of other energy efficiency measures in the state.

The ISP forecasts capture the net effect of gas and electricity fuel switching and energy efficiency behaviours.

## A10.4.3 The need for gas system developments

A reliable gas supply is as critical to Australia's economy as the reliability of electricity supply. AEMO's 2020 GSOO<sup>26</sup> indicates that the adequacy of gas supply and transmission infrastructure to meet gas demand is tight; particularly as gas supply from existing and committed gas developments are forecast to decline by about 35% (163 PJ) over the next five years. With no additional developments, the GSOO concludes that there would be a shortfall in gas supply in eastern and south-eastern states from 2023-24.

An optimal development path that does not consider the co-optimisation of gas and electricity infrastructure development is at risk of ignoring key costs for consumers. For example, significant new GPG development may not be cost effective if significant gas infrastructure needs to be developed to deliver gas to the power station, or if the increase in gas demand creates additional risks of gas supply shortfalls.

It is for this reason that AEMO's integrated gas-electricity market (IM) modelling<sup>27</sup> is an essential first step in the development of the ISP. Due to the bilateral impact of investment decisions in gas and electricity sectors on each other, the IM model considers several investment options in both sectors to optimise the developments required for the whole energy system. Figure 3 shows the new gas developments required each year under the Central scenario in this ISP.

<sup>25</sup> At [https://aemo.com.au/-/media/files/gas/national\\_planning\\_and\\_forecasting/gsoo/2020/2020-gas-statement-of-opportunities.pdf?la=en](https://aemo.com.au/-/media/files/gas/national_planning_and_forecasting/gsoo/2020/2020-gas-statement-of-opportunities.pdf?la=en).

<sup>26</sup> At [https://aemo.com.au/-/media/files/gas/national\\_planning\\_and\\_forecasting/gsoo/2020/2020-gas-statement-of-opportunities.pdf?la=en](https://aemo.com.au/-/media/files/gas/national_planning_and_forecasting/gsoo/2020/2020-gas-statement-of-opportunities.pdf?la=en).

<sup>27</sup> For more information on the models used to produce the 2020 ISP, see Appendix 9.

**Figure 3 Indicative new gas developments required each year, under Central scenario**

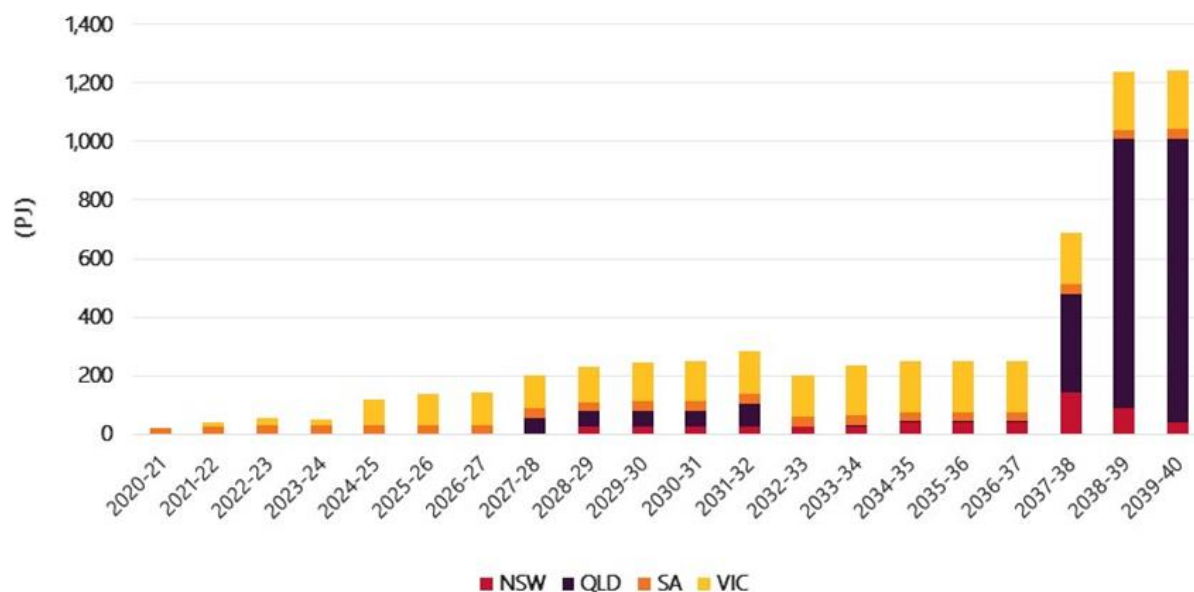

Note. The ISP allows development of fields at a time that minimises total system costs. In some cases, this may be earlier than the timing of the shortfalls identified by the GSOO. The ISP’s gradual development of new gas sources ensures new supplies are available prior to the decline of existing sources.

Gas pipeline expansions or alternative gas infrastructure is forecast to be necessary to source and deliver this new gas supply. East coast gas import terminals would reduce the need for pipeline development and complement the seasonality of domestic production by securing a reliable supply in winter (typically the time of peak domestic gas demand for heating), when the demand in the northern hemisphere is typically low (during the northern hemisphere summer). However, import terminals increase the exposure of domestic customers to the dynamics of the international gas market, which may result in higher volatility in domestic gas prices, compared to pipeline developments and development of domestic gas fields.

For more details on gas reserves and infrastructure adequacy, refer to the 2020 GSOO.

The need for new gas developments is also being recognised by state governments:

- In January 2020, the New South Wales Government signed a Memorandum of Understanding with the Commonwealth Government agreeing to work together to develop options to increase gas supply into New South Wales. This included a target to inject additional 70 PJ of gas a year into the New South Wales market. The options for new gas could come from a variety of different projects, including import terminals at Port Kembla or Port of Newcastle, and the Narrabri gas project (which includes both field and pipeline developments).
- In March 2020, the Victorian Government announced that the ban on onshore conventional gas exploration and development would be lifted from July 2021. Until exploration in these new areas commences, the size of the resources and thus the potential impact on supply adequacy remains uncertain.

# A10.5. Energy efficiency

## Key energy efficiency insights

- Energy efficiency reduces costs by avoiding or delaying investment in generation, transmission and distribution assets.
- Improvements in the thermal performance of buildings and efficiency of appliances and equipment can deliver significant energy savings critical for achieving decarbonisation policies and there are wider economic and health benefits for consumers.
- The 2020 ISP incorporates varying energy efficiency effects in each scenario. In the Central scenario, energy efficiency reduces electricity consumption by 23.6 TWh or by 10% in 2038-39 below business as usual. Higher savings of 38 TWh are achievable by 2038-39 in the Step Change scenario, representing a 13.4% reduction. In the Slow Change scenario, 19.3 TWh of savings are estimated for 2038-39, representing a 10% reduction.
- Targeted energy efficiency measures could potentially reduce peak demand in the future.

Energy efficiency offers the potential to significantly reduce costs in the industry by avoiding or delaying investment in generation, transmission and distribution assets. Energy efficiency offers the potential for reducing energy consumption from the power system as much as distributed PV. Energy efficiency is also one of the most significant means to achieve decarbonisation policies. The International Energy Agency (IEA) estimates that energy efficiency could provide over 40% of abatement required to meet the Paris Agreement and limit global warming to 1.5°C<sup>28</sup>.

For the householder, energy efficiency delivers lower energy bills, and potential health benefits for building occupants by improving thermal comfort using less energy, especially in cold and warmer climates.

The IEA has made energy efficiency a top strategic priority, forming the Global Commission for Urgent Action on Energy Efficiency (Commission) in June 2019. The Commission has more recently considered the role of energy efficiency in improving the effectiveness of government stimulus packages in response to the COVID-19 crisis, where energy efficiency actions could contribute to job creation, reduce emissions and reduce energy costs<sup>29</sup>. In Australia, there are similar calls for action to invest in energy efficiency and energy management as part of our economic recovery, and to bolster Australia's lagging energy productivity<sup>30</sup>.

## A10.5.1 Energy efficiency in the ISP

The 2020 ISP incorporates energy efficiency into the annual energy consumption forecasts, by considering mandatory and voluntary measures that improve the thermal performance of buildings and reduce energy use in appliances and equipment. For the 2020 ISP, the measures include:

<sup>28</sup> See <https://www.iea.org/reports/multiple-benefits-of-energy-efficiency/emissions-savings#abstract> (accessed 26 June 2020).

<sup>29</sup> See <https://www.iea.org/articles/energy-efficiency-and-economic-stimulus> (accessed 26 June 2020).

<sup>30</sup> See <https://www.eec.org.au/news/eec-news/article/building-a-stronger-and-cleaner-post-pandemic-australia> (accessed 26 June 2020).



- Building energy performance requirements contained in the Building Code of Australia (BCA) 2006, BCA 2010, the National Construction Code (NCC) 2019, and, for the Step Change scenario, higher building performance requirements in the future. Energy savings occur because less energy is consumed to heat or cool higher-performing buildings. The savings also capture fuel switching between gas and electricity for space heating. Building rating and disclosure schemes such as the National Australian Built Environment Rating System (NABERS) and Commercial Building Disclosure (CBD).
- The Equipment Energy Efficiency (E3) program of mandatory energy performance standards and/or labelling for different classes of appliances and equipment. The Step Change scenario also considers additional measures that are in proposal stage or are currently suspended but could be reactivated.
- State-based schemes, including the New South Wales Energy Savings Scheme (ESS), the Victorian Energy Upgrades (VEU) program, and the South Australian Retailer Energy Efficiency Scheme (REES).
- Former Commonwealth Government programs, including The Home Insulation Program and Energy Efficiency Opportunities Program.

The energy efficiency forecast for the 2020 ISP was developed in 2019, based on the most recent information available at that time. In 2019 AEMO engaged Strategy.Policy.Research (SPR) to support the development of these forecasts, and the published SPR report<sup>31</sup> complements the 2019 ESOO and provides additional commentary on the forecasts.

In the Central scenario, savings equate to 23.6 TWh from the 2018-19 base year, or approximately 10% less energy consumption by 2038-39 than business as usual. Additional measures, representing feasible yet ambitious future standards for buildings and equipment<sup>32</sup> to drive greater savings, are included in the Step Change scenario. This results in approximately 38 TWh of forecast savings by 2038-39, or approximately 13.4% less energy consumed. The Slow Change scenario is forecast to deliver 19.3 TWh of savings by 2038-39 or 10% less consumption and assumes similar energy efficiency measures as the Central scenario, under lower economic and population growth settings. In all scenarios, energy efficiency delivers a similar magnitude of avoided consumption from the grid to distributed PV.

Since these energy efficiency forecasts were released, the New South Wales Government has announced a commitment to extend the ESS to 2050 and increase the scheme's target<sup>33</sup>. The South Australian Government has also undertaken a review of the REES and is considering recommendations to extend the scheme by 10 years to 2030 and to expand the scope of eligible activities<sup>34</sup>. These new developments are not considered in the ISP, though will be incorporated into the energy efficiency forecasts for the 2020 ESOO. The 2020 ESOO also considers wider fuel switching impacts on residential appliance uptake related to space and water heating.

---

<sup>31</sup> Strategy.Policy.Research, Energy Efficiency Forecasts 2019-2041, available at: [https://www.aemo.com.au/-/media/Files/Electricity/NEM/Planning\\_and\\_Forecasting/Inputs-Assumptions-Methodologies/2019/StrategyPolicyResearch\\_2019\\_Energy\\_Efficiency\\_Forecasts\\_Final\\_Report.pdf](https://www.aemo.com.au/-/media/Files/Electricity/NEM/Planning_and_Forecasting/Inputs-Assumptions-Methodologies/2019/StrategyPolicyResearch_2019_Energy_Efficiency_Forecasts_Final_Report.pdf).

<sup>32</sup> The two measures include future changes to the National Construction Code and activities under the Equipment Energy Efficiency program that are in proposal stage or are currently suspended but could be reactivated.

<sup>33</sup> See <https://energy.nsw.gov.au/media/2031/download>.

<sup>34</sup> See [http://www.energymining.sa.gov.au/\\_data/assets/pdf\\_file/0008/356228/2019\\_REES\\_Review\\_Report.pdf](http://www.energymining.sa.gov.au/_data/assets/pdf_file/0008/356228/2019_REES_Review_Report.pdf).

# A10.6. Bioenergy

Bioenergy is recognised as an alternative renewable resource that has potential to provide energy to consumers for heat and power. It can be used in solid, liquid and gaseous forms, and has the potential to contribute to decarbonisation of the gas supply.

Biogas is generated from the anaerobic (oxygen-free) digestion of organic matter produced by agriculture, food production and waste and water processing, and is a mixture of methane, CO<sub>2</sub> and other gases. From biogas, biomethane can be produced (which is a near pure methane source suitable for injection into gas grids). Biomethane derived from processing of biogas could provide opportunities for energy storage and could replace some natural gas for heating in domestic and industrial applications.

The biogas sector is developing globally and a series of reports exploring the potential of the sector have been released. These include:

- The Australian bioenergy and energy from waste market by CEFC<sup>35</sup>.
- Outlook for biogas and biomethane by IEA<sup>36</sup>.
- Biogas Opportunities for Australia commissioned by Bioenergy Australia<sup>37</sup>.
- Bioenergy State of the Nation Report commissioned by Bioenergy Australia<sup>38</sup>.

Around the world, the biogas market is driven by countries such as Germany, the United Kingdom, the United States and China<sup>36</sup>. IEA research indicates that “future production of green gas may account for as much as 26% of current natural gas demand in Ireland, 24% in the Netherlands, 8% in the UK, 44% in Italy and 75% in Denmark”<sup>39</sup>.

While Australia’s biogas potential has been estimated at around 9% of its total energy consumption in 2016-17<sup>36</sup>, AEMO’s ISP does not directly model bioenergy as an alternative energy source. ARENA is currently developing a Bioenergy Roadmap, which aims to outline the potential future role for bioenergy in Australia’s energy transition<sup>40</sup>, and will help to clarify the potential role of bioenergy in the Australian energy mix. In the meantime, AEMO is monitoring developments in bioenergy and its potential impact on gas and electricity sectors, and where this becomes material, it will be considered in future analysis.

---

<sup>35</sup> CEFC. The Australian bioenergy and energy from waste market. 2015 at <https://www.cefc.com.au/media/107567/the-australian-bioenergy-and-energy-from-waste-market-cefc-market-report.pdf>.

<sup>36</sup> IEA. Outlook for biogas and biomethane, 2020, at <https://www.iea.org/reports/outlook-for-biogas-and-biomethane-prospects-for-organic-growth>.

<sup>37</sup> Bioenergy Australia. Biogas Opportunities for Australia, March 2019 at <https://cdn.revolutionise.com.au/cups/bioenergy/files/2za1rgxbisjqxcme.pdf>.

<sup>38</sup> Bioenergy Australia Bioenergy state of the nation report. November 2018 at <https://cdn.revolutionise.com.au/news/vabsvwo5pa8jnsqs.pdf>.

<sup>39</sup> Wall D.M. Dumont, M. Murphy, J. 2018 Green Gas Facilitating a future green gas grid through the production of renewable gas. IEA Bioenergy p27.

<sup>40</sup> ARENA. 2020. Bioenergy Roadmap website: <https://arena.gov.au/knowledge-innovation/bioenergy-roadmap/#read-the-overview>.