

Trip of Alcoa Portland No. 1 220 kV Busbar on 30 November 2021

May 2022

Reviewable Operating Incident
Report under the National
Electricity Rules





Important notice

Purpose

AEMO has prepared this report in accordance with clause 4.8.15(c) of the National Electricity Rules, using information available as at the date of publication, unless otherwise specified.

Disclaimer

AEMO has made every reasonable effort to ensure the quality of the information in this report but cannot guarantee its accuracy or completeness. Any views expressed in this report may be based on information given to AEMO by other persons.

Accordingly, to the maximum extent permitted by law, AEMO and its officers, employees and consultants involved in the preparation of this document:

- make no representation or warranty, express or implied, as to the currency, accuracy, reliability or completeness of the information in this document; and
- are not liable (whether by reason of negligence or otherwise) for any statements or representations in this document, or any omissions from it, or for any use or reliance on the information in it.

Contact

If you have any questions or comments in relation to this report, please contact AEMO at system.incident@aemo.com.au.

The NEM operates on Australian Eastern Standard Time (AEST). All times in this report are in AEST.

Abbreviations

Abbreviation	Term
AEMC	Australian Energy Market Commission
AEMO	Australian Energy Market Operator
AEST	Australian Eastern Standard Time
APD	Alcoa Portland
kV	Kilovolt
MW	Megawatts
NEM	National Electricity Market
NER	National Electricity Rules
TNSP	Transmission Network Service Provider

Incident review

This reviewable operating incident¹ report is prepared in accordance with clause 4.8.15(c) of the National Electricity Rules (NER). It has been prepared using information provided by Portland Aluminium² and from AEMO systems.

Table 1 Summary of event – Trip of No. 1 220 kV Alcoa Portland busbar

Details	
Reviewable operating incident type	Non-credible contingency event impacting critical transmission elements.
Incident details	This report relates to a reviewable operating incident ³ that occurred on 30 November 2021 in Victoria. The incident involved the trip of the Alcoa Portland (APD) No. 1 220 kV busbar.
Incident classification	Procedural error/lack of procedures.
Generation impact	Nil
Customer load impact	Nil
Pre-incident conditions	Contractor staff were present at APD 220 kV substation setting up a water transfer pump on site. A contractor was carrying out general insulator washing of Blue, White, and Red phases of isolator 2611 adjacent to the APD No. 1 220 kV busbar immediately prior to the event.
Incident key events	<ol style="list-style-type: none"> At 1133 hrs on 30 November 2021, No. 1 220 kV busbar tripped. This also removed Transformer L7 from service (see Figure 1). From 1154 hrs to 1156 hrs at APD 220 kV substation, isolators 2612 and 2611 were opened to prepare for the return to service of the No. 1 220 kV busbar. At 1206 hrs, the No. 1 220 kV busbar and Transformer L7 were restored following CB2210, CB2110 and CB2510 closure.
Incident cause	Post-incident investigation confirmed that a flashover occurred on the red phase of isolator 2611, causing No. 1 220 kV busbar to trip. The flashover was caused by existing salt contamination on isolator 2611’s insulators and overspray/misting that landed on the insulators during the washing of adjacent equipment.
Power system response (facilities and services)	<p>On 30 November 2021, Alcoa Portland contractors were carrying out planned insulator washing at the APD 220 kV substation. The contractors had just finished washing isolator 2611 Blue and White phases and were moving their equipment to access the isolator 2611 Red phase. At 1133 hrs, a flashover occurred on isolator 2611’s Red phase. As a result, busbar protection at APD 220 kV operated to clear the fault, resulting in disconnection of APD No. 1 220 kV busbar and Transformer L7.</p> <p>To prepare for return of the No. 1 220 kV busbar to service, at 1154 hrs, Portland Aluminium staff opened isolator 2612. At 1156 hrs, isolator 2611 was opened and busbar protection trip relays were reset. Following these actions, at 1206 hrs, No. 1 220 kV busbar and Transformer L7 were returned to service.</p> <p>Post-incident investigation by Portland Aluminium has confirmed that:</p> <ul style="list-style-type: none"> Prior to the incident there was no indication that a flashover on isolator 2611 was likely. The flashover occurred in the middle of the insulator stack on isolator 2611’s Red phase. This was confirmed through visual inspection (see Figure 2). A number of factors contributed to this incident including: <ul style="list-style-type: none"> Salt contamination of isolator 2611 insulators. A rapid change in prevailing wind direction, from North around to South-East, around the time of the incident.

¹ Reviewable operating incidents are defined by NER clause 4.8.15(a) and the AEMC Reliability Panel Guidelines for Identifying Reviewable Operating Incidents.

² Portland Aluminium is the owner of the Alcoa Portland 220 kV substation.

³ See NER clause 4.8.15(a)(1)(i), as the event relates to a non-credible contingency event; and the AEMC Reliability Panel Guidelines for Identifying Reviewable Operating Incidents.

Details	
	<ul style="list-style-type: none"> – Positioning of the insulator washing truck which allowed overspray/misting across isolator 2611 before this isolator had been fully washed.
Rectification	<p>Immediately after the incident and prior to the return to service of the No. 1 220 kV busbar and Transformer L7, Portland Aluminium identified the cause of the incident and isolated the affected equipment.</p> <p>Portland Aluminium’s post-incident review identified the following actions to reduce the risk of future occurrence:</p> <ul style="list-style-type: none"> • Completion of Insulation testing of isolator 2611 insulators. • Insulator washing procedures have been updated to ensure that atmospheric conditions are monitored and taken into account throughout the activity. • Insulator washing procedures have been reviewed to reset good practice standards and outline instructions for when atmospheric conditions change. • In addition, Portland Aluminium has confirmed it will advise AEMO of similar risks in future, in accordance with NER Clause 4.2.3A.
Power system security	<p>The power system remained in a secure operating state throughout this incident and the Frequency Operating Standard was⁴ met for this incident.</p>
Reclassification	<p>AEMO assessed whether to reclassify this incident as a credible contingency event⁵.</p> <p>The cause of this incident was identified and rectified by Portland Aluminium prior to the return of the No. 1 220 kV busbar to service, therefore AEMO correctly identified that reclassification was not required.</p>
Market information	<p>AEMO issued Market Notice 92829 at 1205 hrs on 30 November 2021 – advice of inter-regional transfer limit variation (this market notice was issued in accordance with NER requirements).</p>
Conclusions	<p>AEMO has concluded that:</p> <ol style="list-style-type: none"> 1. The trip of Alcoa Portland No. 1 busbar was caused by a flashover on the Red phase of isolator 2611, causing the No. 1 220 kV busbar to trip. 2. The flashover was caused by salt contamination on isolator 2611’s insulators and overspray/misting that landed on the insulators during the washing of adjacent equipment. 3. Portland Aluminium was able to identify the cause of the incident prior to the equipment’s return to service. To mitigate the risk of re-occurrence Portland Aluminium has completed testing of isolator 2611 and reviewed its insulator washing procedures. 4. The power system remained in a secure operating state throughout this incident and the Frequency Operating Standard was met for this incident.

⁴ Frequency Operating Standard, effective 1 January 2020, available at <https://www.aemc.gov.au/media/87484>.

⁵ AEMO is required to assess whether or not to reclassify a non-credible contingency event as a credible contingency event – NER clause 4.2.3A(c) – and to report how the reclassification criteria were applied – NER clause 4.8.15(ca).

Figure 1 Post-incident diagram (all elements were in service prior to the incident)

Alcoa Portland Substation

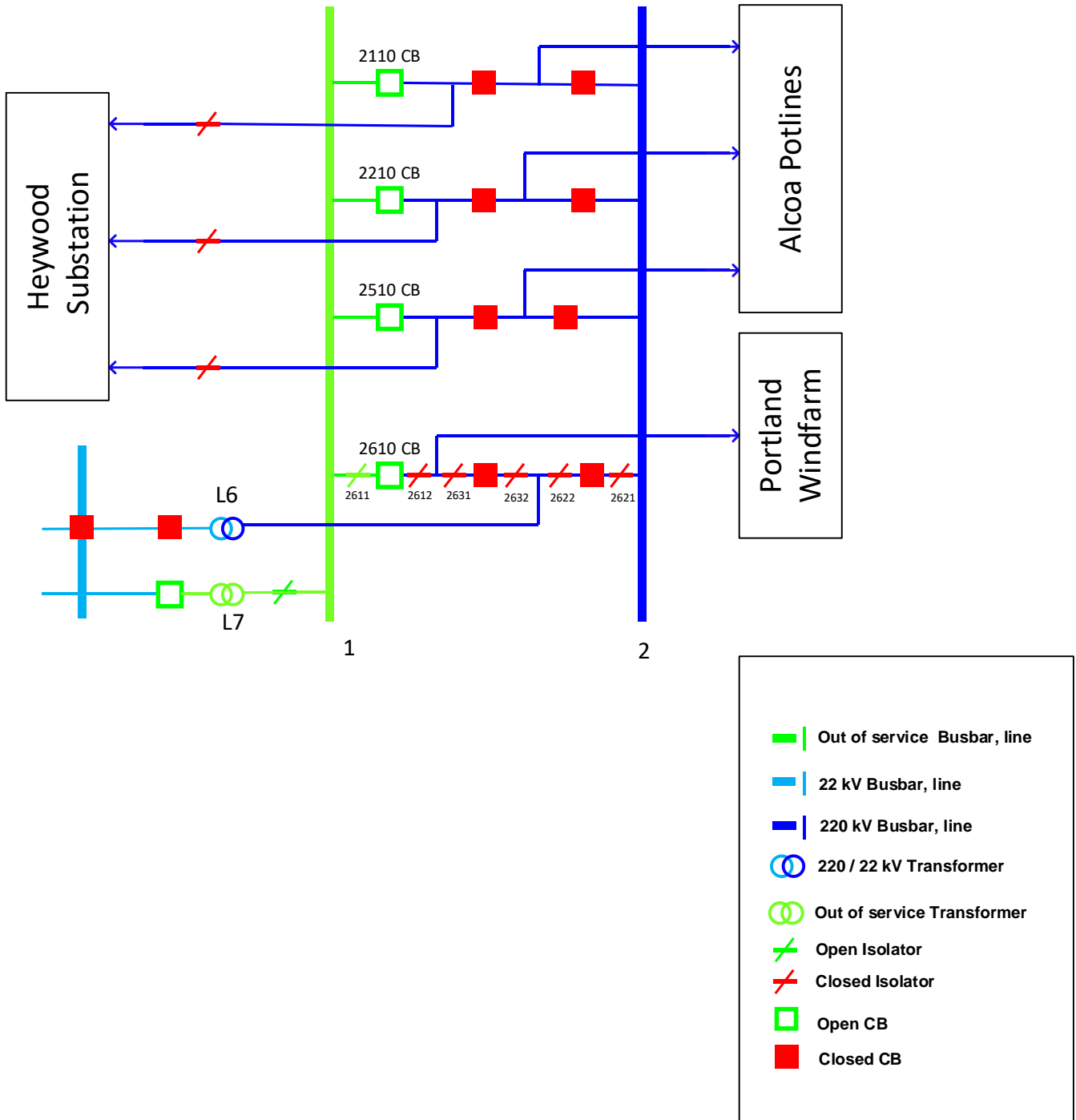



Figure 2 Visual Inspection of Isolator 2611 insulators



Red Phase – East side insulators (South aspect)



Red Phase – East side insulators (West aspect)