



Powerlink Queensland

# Preparatory Activities – QNI Connect

2024 Integrated System Plan

June 2023

# Contents

- Contents ..... 2
- Executive summary ..... 3
- Preliminary Engineering Design ..... 5
  - Single Line Diagrams ..... 5
    - 330kV Single Circuit from Bulli Creek ..... 5
    - 330kV Single Circuit from Braemar ..... 6
    - 330kV Double Circuit with/without VTL ..... 7
    - 500kV Double Circuit..... 8
  - Site Layout ..... 9
  - Asset List..... 9
  - Network Parameters and Transfer Limits ..... 9
    - Network Parameters..... 9
    - Transfer Limits..... 11
  - Corridor / Route Selection..... 14
- Project schedule and staging ..... 16
- Cost estimates ..... 17
- Approvals and stakeholders ..... 21
  - Stakeholder engagement plan ..... 21
  - Relevant planning overlays..... 21
  - Estimate of planning approval complexity..... 21
- References ..... 22

## Executive summary

The 2022 Integrated System Plan (ISP) [1] defined the projects and timing of 22 network investments in the optimal development path (ODP). Future ISP projects are a subset of these projects that are not yet ‘actionable’ under the ISP Rules, but are expected to become actionable in the future. Those projects categorised as ‘future ISP projects’ require the responsible TNSP to carry out preparatory activities including providing a report of these activities to AEMO by 30 June 2023.

QNI Connect is one of the future ISP projects which is described as enabling “approximately 1,000MW transfer capacity between southern Queensland and New England, following development of the New England REZ Transmission Link.”

Powerlink have consulted with Transgrid on a number of options to increase the capacity of QNI. These options also align with long term development plans in both states to host more variable renewable energy (VRE) sources. Figure 1 gives an overview of how one of these options (500kV option 4) connects Queensland and New South Wales as well as traversing Renewable Energy Zones in both states.

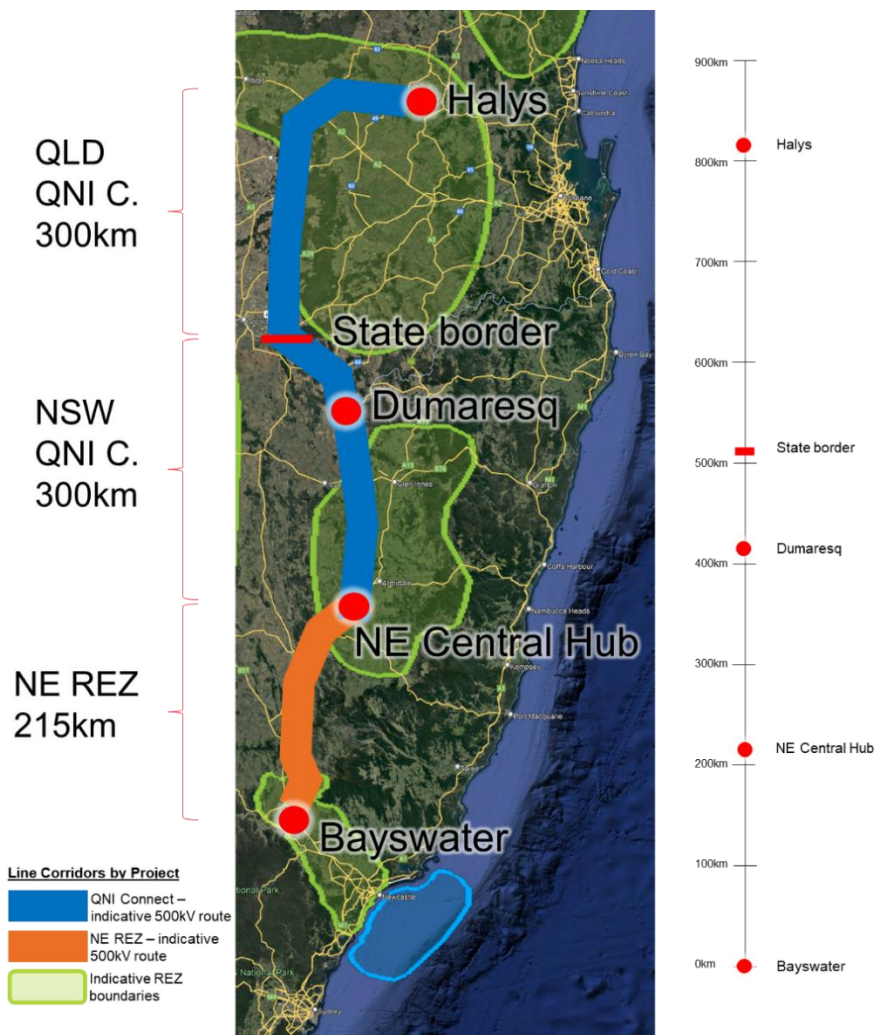

Figure 1 – Overview QNI 500kV Option

In this report, Powerlink presents five QNI Connect options for inclusion in the 2024 ISP analysis. These options have been developed in consultation with Transgrid and AEMO. The five options are:

- 1a. A new 330kV single circuit line from Bulli Creek.
- 1b. A new 330kV single circuit line from Braemar.
2. A new 330kV double circuit line.
3. A new 330kV double circuit line with virtual transmission line (VTL).
4. A new 500kV double circuit line.

Options 1a and 1b both align with option 1 described in Transgrid's QNI Connect ISP Preparatory Activities.

Appendix A5.5.5 of the 2022 ISP [2] describes the future ISP project associated with the QNI Medium project as "new 330 kV double-circuit line (one circuit strung) from locality of Armidale South to Dumaresq to Bulli Creek to Braemar." Powerlink has not included this option but instead has opted for a single circuit option. This is based on the costs and practical constraints associated with stringing the second side of a circuit with the original side in operation.

This report summarises the preparatory activities undertaken by Powerlink for different options to augment the capacity of QNI for the purposes of input to future ISPs.

## Preliminary Engineering Design

### Single Line Diagrams

#### 330kV Single Circuit from Bulli Creek

Figure 2 presents an overview of the proposed works as part of the future ISP project associated with the QNI Connect 330kV single circuit from Bulli Creek Substation (Option 1a).

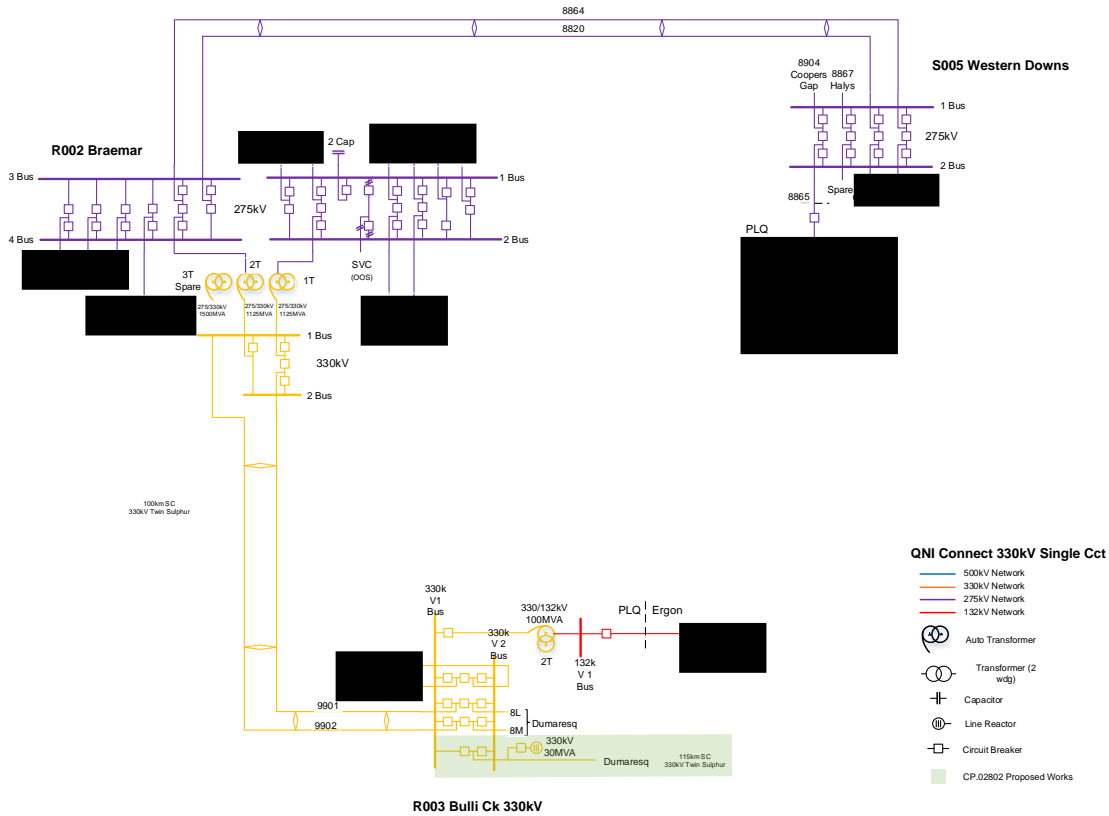

**Figure 2 – Overview of proposed works - 330kV Single Circuit from Bulli Creek**

In addition to the overview presented in Figure 2, a detailed single line diagram has been prepared for Bulli Creek substation to inform estimating. These have been included in the report to AEMO, but not included in the publicly available version of this report.

**Figure 3 – Single line diagram for Bulli Creek Substation (330kV) – 330kV Single Circuit**



### 330kV Single Circuit from Braemar

Figure 4 presents an overview of the proposed works as part of the future ISP project associated with the QNI Connect 330kV single circuit from Braemar Substation (Option 1b).

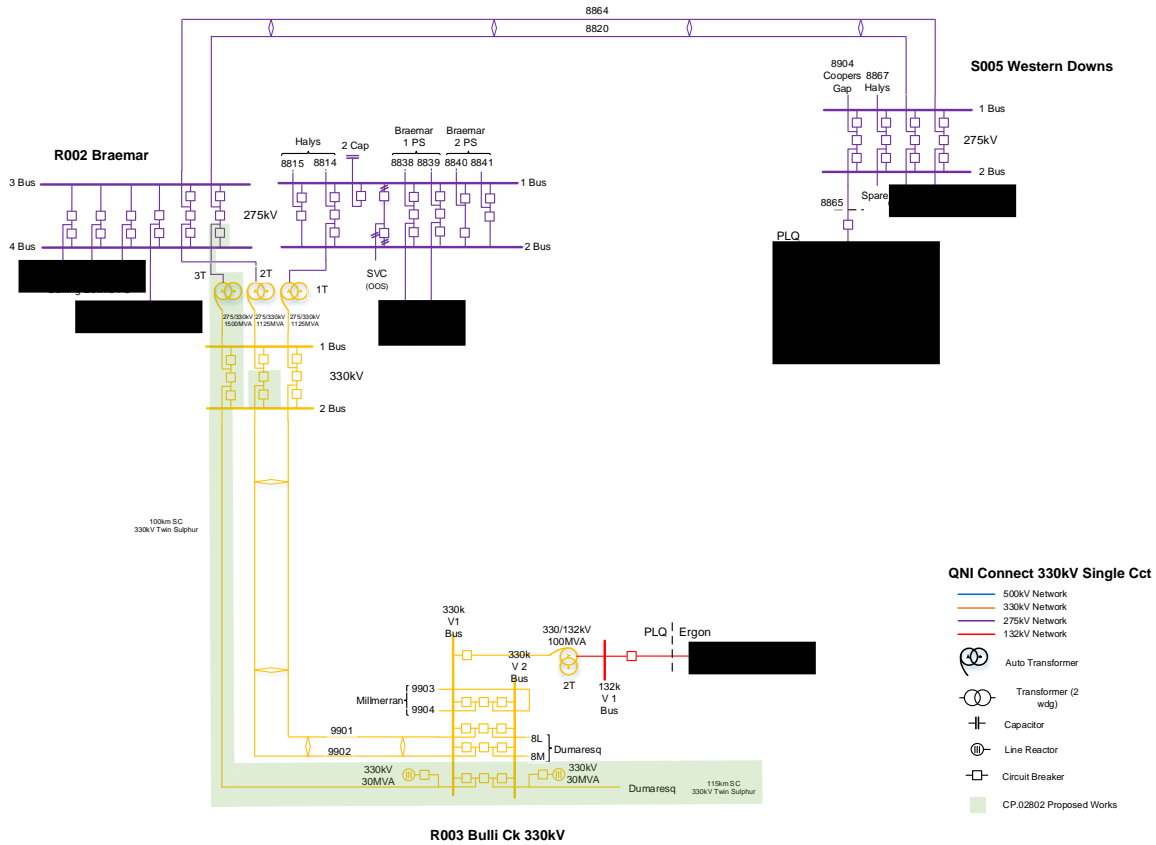

**Figure 4 – Overview of proposed works - 330kV Single Circuit from Braemar**

In addition to the overview presented in Figure 4, detailed single line diagrams have been prepared for each substation to inform estimating. These have been included in the report to AEMO, but not included in the publicly available version of this report.

**Figure 5 – Single line diagram for Braemar Substation (330kV) – 330kV Single Circuit**

**Figure 6 – Single line diagram for Braemar Substation (275kV West) – 330kV Single Circuit**

**Figure 7 – Single line diagram for Bulli Creek Substation (330kV) – 330kV Single Circuit**

### 330kV Double Circuit with/without VTL

Figure 8 presents an overview of the proposed works as part of the future ISP project associated with the QNI Connect double circuit 330kV options (Options 2 and 3).

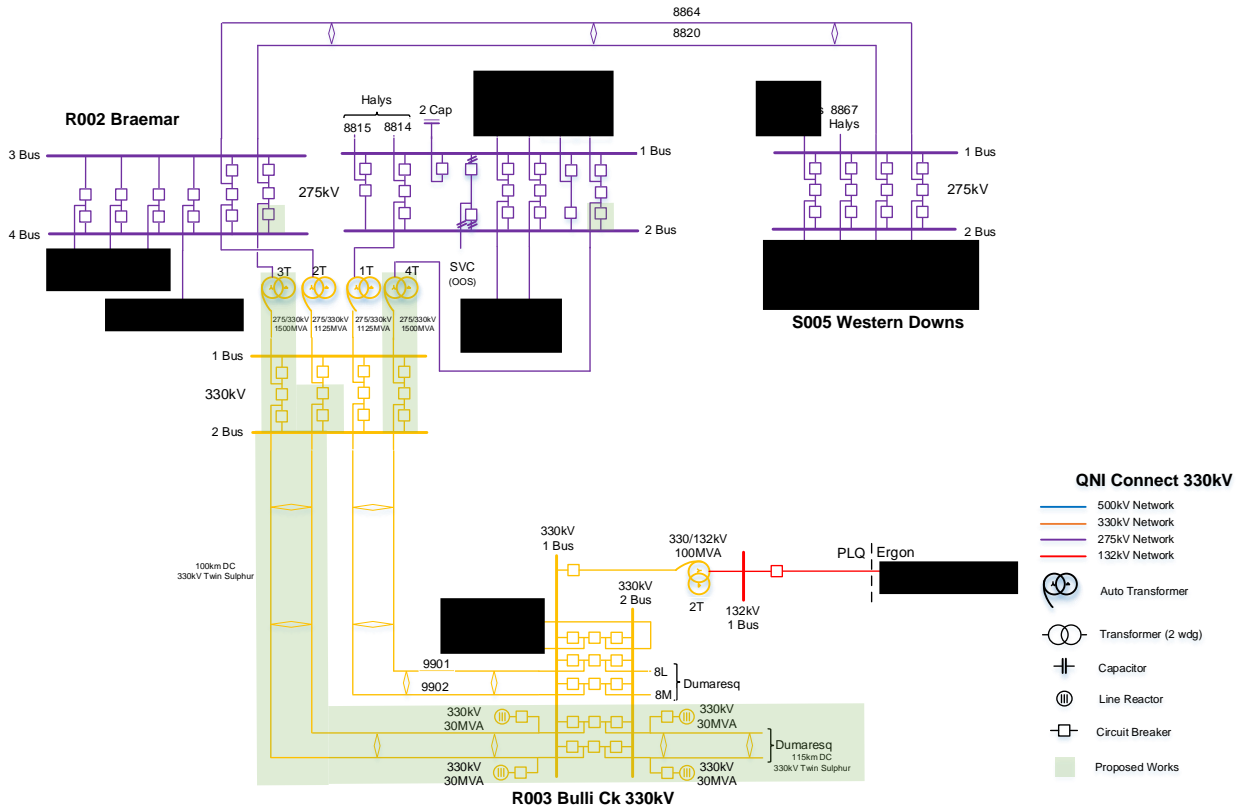

**Figure 8 – Overview of proposed works – 330kV Double Circuit**

In addition to the overview presented in Figure 8, detailed single line diagrams have been prepared for each substation to inform estimating. These have been included in the report to AEMO, but not included in the publicly available version of this report.

**Figure 9 – Single line diagram for Braemar Substation (330kV) – 330kV Double Circuit**

**Figure 10 – Single line diagram for Braemar Substation (275kV East) – 330kV Double Circuit**

**Figure 11 – Single line diagram for Braemar Substation (275kV West) – 330kV Double Circuit**

**Figure 12 – Single line diagram for Bulli Creek Substation (330kV) – 330kV Double Circuit**

### 500kV Double Circuit

Figure 13 presents an overview of the proposed works as part of the future ISP project associated with the QNI Connect double circuit 500kV option (Option 4).

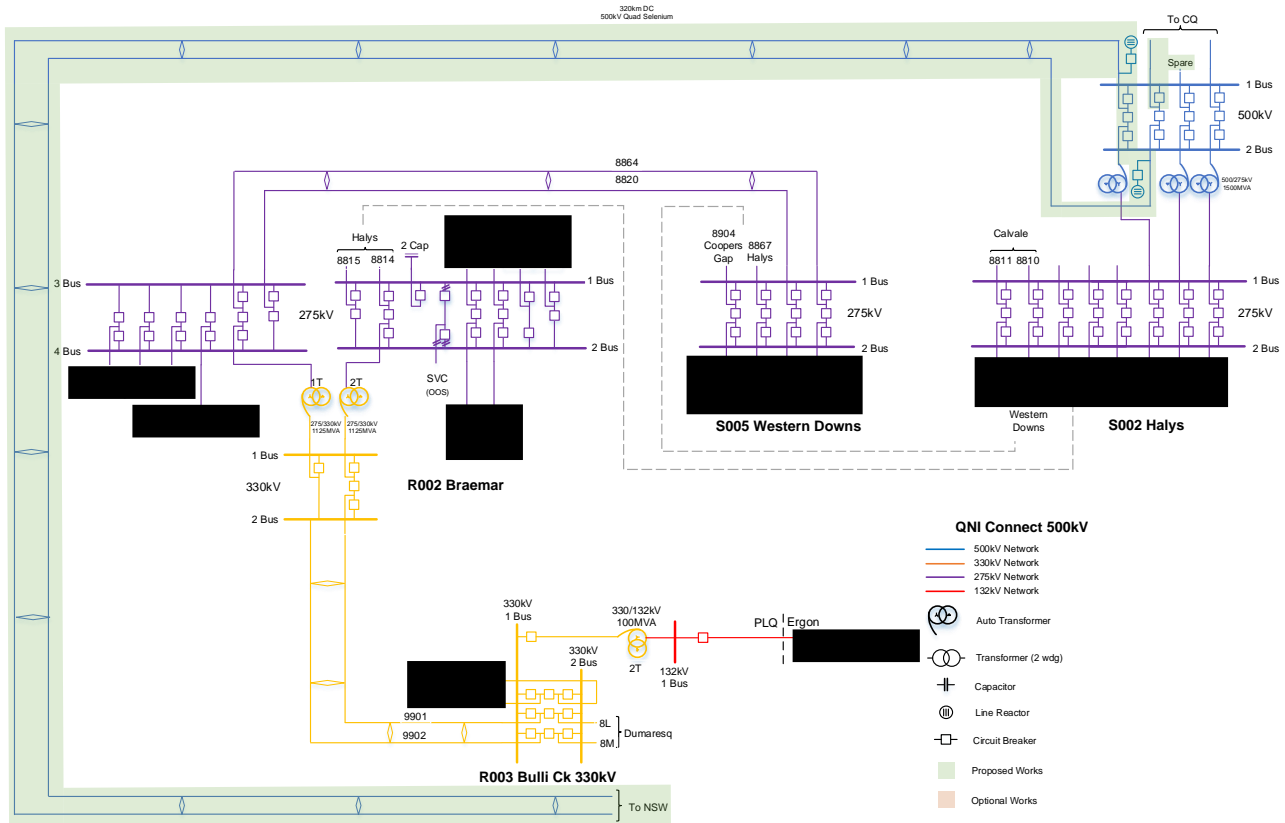

**Figure 13 – Overview of proposed works – 500kV Double Circuit**

In addition to the overview presented in Figure 13, a detailed single line diagram for Halys has been prepared to inform estimating. This has been included in the report to AEMO, but not included in the publicly available version of this report.

This option is contingent on the establishment of a 500kV substation at Halys. Establishment of this substation is planned with the Borumba Pumped Hydro Energy Storage (PHES) project as outlined in the Queensland SuperGrid Infrastructure Blueprint [3] published as part of the Queensland Energy and Jobs Plan.

**Figure 14 – Single line diagram for Halys Substation (500kV) – 500kV Double Circuit**



## Site Layout

To inform estimating, indicative site layout (general arrangement) diagrams have been produced for each substation across all options. However, these have not been presented due to the complexity in the diagrams and the indicative nature of the layout.

## Asset List

The total procurement costs for each broad asset grouping is provided in the cost estimate provided in Tables 11 through 14. Powerlink does not present itemised costs for specific plant items to external parties, as this is commercially sensitive information subject to confidentiality.

## Network Parameters and Transfer Limits

### Network Parameters

There are multiple options that involve augmenting the existing 330kV QNI network as shown in Figures 2, 4 and 8.

Tables 1 and 2 present the electrical network parameters required to model the Queensland component of these options when performing loadflow, fault level and dynamic analysis.

**Table 1 – 330kV options transmission line electrical parameters (using 100MVA/330kV base quantities)**

Circuit	R	X	B	R0	X0	B0
Braemar – Bulli Creek 330kV feeder	0.210%	2.489%	38.638%	1.504%	7.036%	22.248%
Bulli Creek – QLD/NSW Border 330kV feeder	0.264%	3.144%	48.776%	1.962%	9.01%	28.011%

The transmission line parameters are consistent with the existing 330kV twin Sulphur double circuit line between Braemar and Bulli Creek (100km) and Bulli Creek to the Queensland/NSW border (115km). Thermal ratings would be consistent with the existing lines with summer/shoulder/winter normal ratings of 1,246/1,358/1,434MVA and summer/shoulder/winter emergency ratings of 1,456/1,568/1,653MVA.

**Table 2 – 330kV options transformer electrical parameters (using 100MVA/330kV base quantities)**

Circuit	R12	X12	R23	X23	R13	X13
1,500MVA 330/275/33kV Braemar transformer (PSS®E connection code 113 auto wye-wye-delta)	0.004%	0.448%	0.249%	8.177%	0.273%	9.285%
	R01	X01	R02	X02	R03	X03
	0.036%	0.608%	0.001%	-0.197%	0.218%	7.867%

Thermal ratings of the 3 winding transformers assumed a normal cyclic rating of 1,500MVA and emergency cyclic rating of 1,650MVA.

For all of the 330kV options, 30MVAR line reactors are to be connected to each new circuit connected to Bulli Creek Substation (between 1 and 4 reactors depending on the option).

The 500kV double circuit option is shown in Figure 13. Table 3 and Table 4 present the electrical network parameters required to model the Queensland component of this option.

**Table 3 – 500kV options transmission line electrical parameters (using 100MVA/500kV base quantities)**

Circuit	R	X	B	R0	X0	B0
Halys – QLD/NSW Border 500kV feeder	0.209%	3.312%	355.07%	1.322%	9.647%	199.59%

The assumed route length of the 500kV option is 320km and these parameters are based on quad Selenium conductor double circuit line. Powerlink does not currently have any 500kV circuits in its network. The current design for these lines have summer/shoulder/winter normal ratings of 3,356/3,619/3,821MVA and summer/shoulder/winter emergency ratings of 3,767/4,042/4,255MVA.

**Table 4 – 500kV options transformer electrical parameters (using 100MVA/500kV base quantities)**

Circuit	R12	X12	R23	X23	R13	X13
1,500MVA 500/275/33kV Halys transformer (PSS®E connection code 113 auto wye-wye-delta)	0.009%	0.870%	0.091%	5.470%	0.086%	7.340%
	R01	X01	R02	X02	R03	X03
	0.002%	1.420%	0.006%	-0.290%	0.075%	5.274%

There are no new transformers included in the 500kV option as the Halys 500kV substation is assumed to be established in the Borumba PHES project. Parameters have been included here for completeness. Thermal ratings of the 3 winding transformers assumed a normal cyclic rating of 1,500MVA and emergency cyclic rating of 1,650MVA.

For the 500kV option, 120MVAR line reactors are to be connected to each new circuit connected at Halys Substation (2 reactors in total).

## Transfer Limits

Power system analysis has been undertaken to increase the accuracy of applicable limits prior to and after the five QNI Connect options as part of the preparatory activities.

### *Assumptions and Methodology*

QNI transfer limits are generally sensitive to the location and magnitude of generation and load. AEMO has provided Powerlink and Transgrid with three PSS<sup>®</sup>E cases representing different future system conditions which have been labelled as Summer Peak, Summer Typical and Winter Typical. These cases are the starting point for all of the analysis.

The following network changes have been applied to each case prior to any analysis:

- The QEJP stage 1 projects have been included. This involves the establishment of 2GW Borumba PHES connected at 500kV to Halys and Woolooga West substations (with 275kV connection from Woolooga West to Woolooga Substation).
- The New England REZ option 1 has been applied to the base case to reflect the most likely development option as advised by Transgrid. Full details of this development are available in Appendix B of the Network Infrastructure Strategy for NSW [4].
- Feeder ratings have been updated to reflect the time of day and seasonal ratings that would apply.

The following definitions and assumptions were made for this analysis:

- The QNI flow is expressed as the MW flow from Bulli Creek into Dumaresq 330kV for the 330kV options. The flow from Halys into the Dumaresq 500kV Substation is also included for the 500kV option.
- The QNI limit corresponds to a limiting condition along any 330kV or 500kV section of the QNI corridor. This includes the 330kV network between Braemar and the New England REZ Central (Hub 5) and the 500kV network between Halys and New England REZ Central (Hub 5).
- In order to find the QNI transfer limit, the generation dispatch of these cases has been modified to reflect plausible future generation dispatches that result in high southerly flows over the interconnector.
- In order to increase the QNI southerly flows to reach network limits, generation in Queensland has been increased with a corresponding decrease in generation in New South Wales. Load was left at levels provided by AEMO's cases.
- The generation merit order assumed for increasing the QNI southerly flow was wind, pumped hydro and then gas in Queensland. Coal generation in the Hunter region of New South Wales was decreased to offset the increased generation in Queensland.
- For the double circuit 330kV with VTL option a 200MW push-pull Battery Energy Storage System (BESS) configuration has been assumed. The limit has been calculated by adding 200MW to the double circuit 330kV limit without VTL option. Different BESS sizes would result in a corresponding limit changes.
- The single number limit is derived from the thermal limit determined using the above assumptions.

- The resulting thermal limit was tested for voltage stability using heuristic measures to determine whether the thermal limit was higher than the voltage stability limit.
- It has been assumed that should transient and oscillatory stability limits be lower, equipment would be tuned or added to raise these limits beyond the calculated steady state limits.

AEMO requested (QNI) limits be specified in a simplified manner (single number/s) that can be used in the Detailed Long-Term (DLT) model. To meet this requirement Powerlink has applied the following methodology to derive the QNI limit for each option and system condition:

1. Calculate thermal limit for each combination of system condition and option.
2. Determine whether voltage stability is likely to set a lower limit than the QNI thermal limit. If so determine a voltage stability limit satisfying heuristic thresholds.
3. Take the minimum of these limits. This results in one limit value for each system condition and option.

#### *Discussion of results*

The three PSS<sup>®</sup>E cases provided by AEMO align with three future system conditions – Summer Maximum, Summer Typical and Winter Typical. In each of these cases there is variation in load and generation dispatch. However all of the cases are evening conditions and as such there is no solar generation available.

For all but one of 330kV scenarios the QNI southerly flow was limited by N-1 thermal constraints between Armidale and New England REZ Central (Hub 5). With the cases provided, the variation of the thermal limits is primarily driven by the output of Sapphire Wind Farm. As generation from Sapphire Wind Farm increases, the available capacity for QNI southerly flow decreases.

The output of New England Solar Farm has a similar impact on the QNI southerly limit. It is anticipated that any new generation or energy storage connected to the network between Armidale and New England REZ Central (Hub 5) would exhibit a similar impact. For example, EnergyCo's Network Infrastructure Strategy [4] has identified a potential pumped hydro project with a capacity of approximately 800MW close to Armidale.

Voltage stability checks on the 330kV options indicate that the thermal limit would likely be lower than the voltage stability limit except in the case of the double circuit option applied to the Summer Peak base case. The thermal limit for this case was 3,250MW, however due to excessive post-contingent reactive power absorption sensitivity to active power flow at this loading level, the limit was revised down to 3,150MW.

For the 500kV option the thermal limit is set by the loss of a 330kV feeder between Bulli Creek and Dumaresq. The loss of this feeder resulted in overloads of the adjacent 330kV feeder. The thermal limit for QNI southerly flow across all cases was 4,200MW, these were moderated down to 3,700MW due to voltage stability heuristics.

The resulting limits are summarised in Tables 5 through 9.

**Table 5 – Transfer limits for 330kV Single Circuit Option from Bulli Creek**

System Condition	Calculated QNI Southerly Limit (MW)		
	Pre Upgrade	Post Upgrade	Limit Increase
Summer Peak	1,450	2,350	900
Summer Typical	1,100	1,900	800
Winter Typical	1,200	2,050	850

**Table 6 – Transfer limits for 330kV Single Circuit Option from Braemar**

System Condition	Calculated QNI Southerly Limit (MW)		
	Pre Upgrade	Post Upgrade	Increase
Summer Peak	1,450	2,350	900
Summer Typical	1,100	1,900	800
Winter Typical	1,200	2,050	850

**Table 7 – Transfer limits for 330kV Double Circuit Option**

System Condition	Calculated QNI Southerly Limit (MW)		
	Pre Upgrade	Post Upgrade	Increase
Summer Peak	1,450	3,150 <sup>1</sup>	1,700
Summer Typical	1,100	2,600	1,500
Winter Typical	1,200	2,900	1,700

**Table 8 – Transfer limits for 330kV Double Circuit with VTL Option**

System Condition	Calculated QNI Southerly Limit (MW)		
	Pre Upgrade	Post Upgrade	Increase
Summer Peak	1,450	3,350 <sup>1</sup>	1,900
Summer Typical	1,100	2,800	1,700
Winter Typical	1,200	3,100	1,900

**Table 9 – Transfer limits for 500kV Double Circuit Option**

System Condition	Calculated QNI Southerly Limit (MW)		
	Pre Upgrade	Post Upgrade	Increase
Summer Peak	1,450	3,700 <sup>1</sup>	2,250
Summer Typical	1,100	3,700 <sup>1</sup>	2,600
Winter Typical	1,200	3,700 <sup>1</sup>	2,500

<sup>1</sup> QNI Southerly limit set by voltage stability rather than thermal ratings.



## Corridor / Route Selection

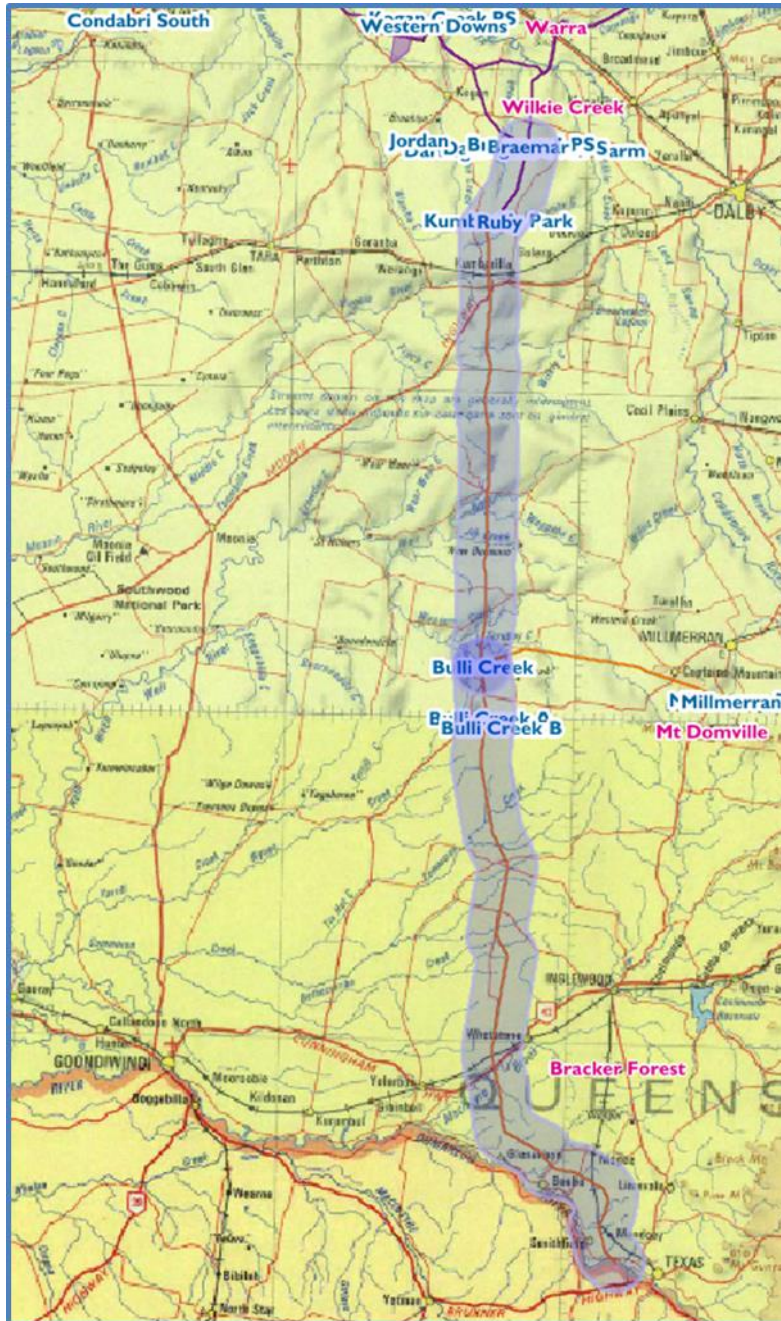

Figure 15 – Indicative corridor for 330kV options

A high-level desktop assessment has been conducted, exploring potential transmission line route options between Braemar and Dumaresq (NSW border crossing) via Bulli Creek. It is concluded that nominally following the existing QNI route, which connects the same substations, is the preferred option, as it is the most direct and is likely to be the lowest cost alternative, both for acquisition and construction phases. This is shown in Figure 15. A notional corridor 20km wide surrounding the existing easement is assumed. Widening the existing easement, or creating a



separate “parallel” easement are both possible within this corridor. A decision regarding separation between existing and proposed lines will be made at a later stage, taking into account all the relevant factors.

No provision is made for land acquisition at either Braemar or Bulli Creek substations. Both existing sites have vacant area available for the required expansion.

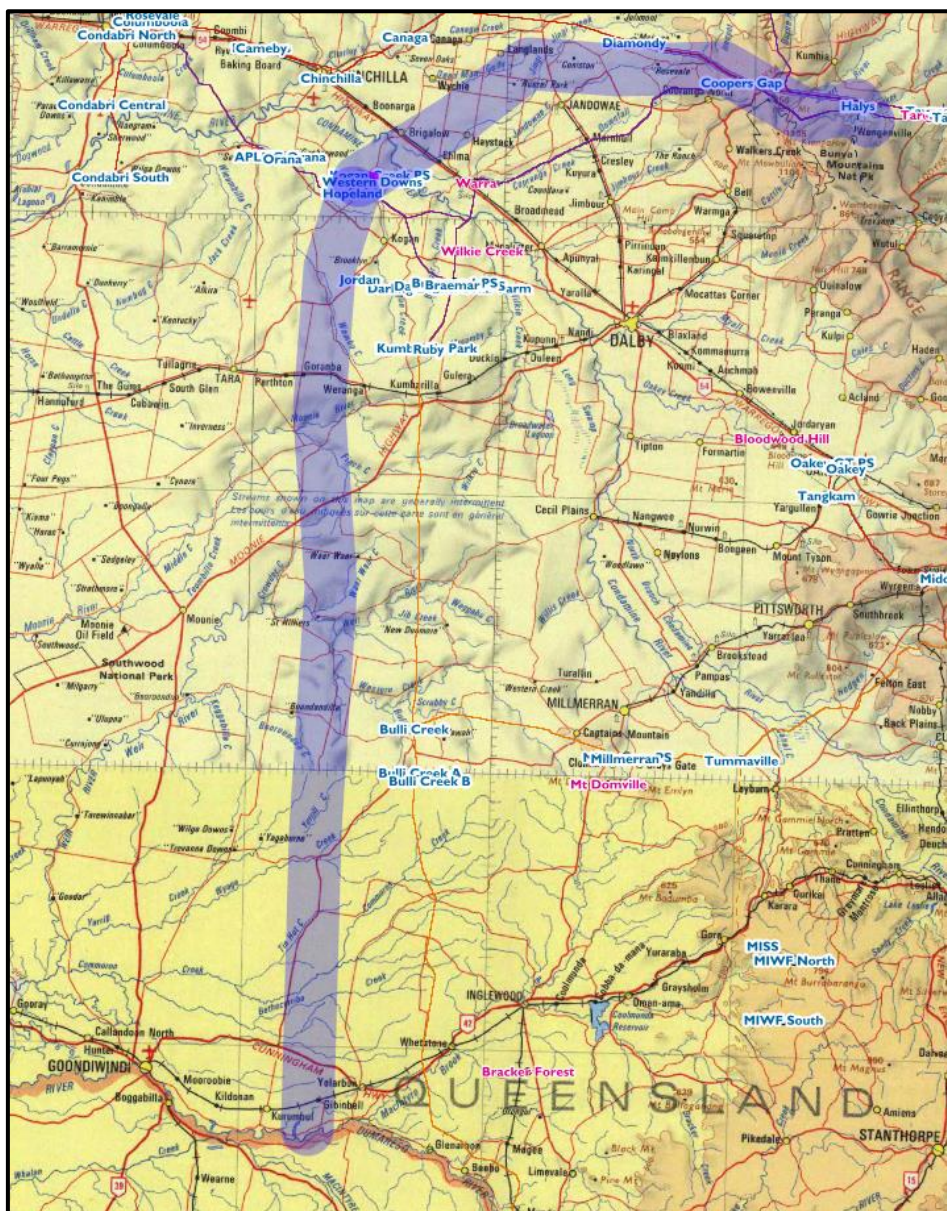

Figure 16 – Indicative corridor for 500kV option

Separation between the existing 330kV and proposed 500kV circuits is desirable for network resilience and security. Given that the 500kV double circuit option will terminate at different substations to the existing 330kV QNI circuits, a separation distance of approximately 20km would be practical. Figure 16 shows the indicative alignment of this option from Halys Substation to the Queensland/NSW border. This route allows for cutting in the QNI feeders at Western Downs if a 500kV substation is established there in the future.

## Project schedule and staging

A high level staging plan for an assumed commissioning date of June 2033 for QNI Connect is presented in Table 10.

**Table 10 – High level schedule and staging**

Activity	Target Completion
Project Approval	June 2025
Property Acquisition	June 2029
Design and Procurement	June 2030
Transmission Line Site Access	June 2030
Transmission Line Construction Complete	January 2033
Substation Construction Complete	June 2033
Commission	June 2033

## Cost estimates

The cost estimates for QNI Connect options are presented in Tables 11 through 14. These are class 5 estimates.

Costs for the battery component of the 330kV Double Circuit with Virtual Transmission Line (VTL) option have not been provided as it was assumed that the VTL would be provided through a network service agreement with existing battery installations.

**Table 11 – Estimate breakdown for 330kV Single Circuit Option from Bulli Creek**

QNI Connect 330kV Single Circuit Option from Bulli Creek	Base Cost
Class 5	\$k, real 2023
<b>Overheads</b>	<b>74,066</b>
Project Management, Coordination and Other Support	8,915
Property Acquisition, Environmental & Cultural Heritage	42,151
Environmental Offsets	23,000
<b>Transmission Lines</b>	<b>225,159</b>
Design	3,022
Procurement	13,723
Construction	207,731
Post Commissioning	683
<b>Substations</b>	<b>20,502</b>
Design	1,190
Procurement	8,078
Construction	7,734
Commissioning	3,476
Post Commissioning	24
<b>Telecoms</b>	<b>259</b>
<b>Network Operations</b>	<b>101</b>
<b>Estimate Total</b>	<b>320,087</b>
<b>Total Contingency</b>	<b>128,035</b>
Mitigated Risk (Known Risk)	64,017
Contingency (Unknown Risk)	64,017
<b>Estimate Total (including Risk &amp; Contingency)</b>	<b>448,122</b>

Table 12 – Estimate breakdown for 330kV Single Circuit Option from Braemar

QNI Connect 330kV Single Circuit Option from Braemar	Base Cost
Class 5	\$k, real 2023
<b>Overheads</b>	<b>160,415</b>
Project Management, Coordination and Other Support	37,723
Property Acquisition, Environmental & Cultural Heritage	79,692
Environmental Offsets	43,000
<b>Transmission Lines</b>	<b>421,241</b>
Design	5,659
Procurement	25,707
Construction	388,594
Post Commissioning	1,281
<b>Substations</b>	<b>106,089</b>
Design	6,364
Procurement	52,491
Construction	39,130
Commissioning	8,020
Post Commissioning	84
<b>Telecoms</b>	<b>456</b>
<b>Network Operations</b>	<b>160</b>
<b>Estimate Total</b>	<b>688,361</b>
<b>Total Contingency</b>	<b>275,344</b>
Mitigated Risk (Known Risk)	137,672
Contingency (Unknown Risk)	137,672
<b>Estimate Total (including Risk &amp; Contingency)</b>	<b>963,705</b>

**Table 13 – Estimate breakdown for 330kV Double Circuit Option with/without VTL Option**

<b>QNI Connect 330kV Double Circuit Option</b>	<b>Base Cost</b>
<b>Class 5</b>	<b>\$k, real 2023</b>
<b>Overheads</b>	<b>208,456</b>
Project Management, Coordination and Other Support	83,321
Property Acquisition, Environmental & Cultural Heritage	82,135
Environmental Offsets	43,000
<b>Transmission Lines</b>	<b>561,659</b>
Design	6,741
Procurement	46,868
Construction	506,769
Post Commissioning	1,281
<b>Substations</b>	<b>164,201</b>
Design	7,332
Procurement	84,244
Construction	58,915
Commissioning	13,626
Post Commissioning	84
<b>Telecoms</b>	<b>456</b>
<b>Network Operations</b>	<b>160</b>
<b>Estimate Total</b>	<b>934,932</b>
<b>Total Contingency</b>	<b>373,973</b>
Mitigated Risk (Known Risk)	186,986
Contingency (Unknown Risk)	186,986
<b>Estimate Total (including Risk &amp; Contingency)</b>	<b>1,308,904</b>



**Table 14 – Estimate breakdown for 500kV Double Circuit Option**

<b>QNI Connect 500kV Double Circuit Option</b>	<b>Base Cost</b>
<b>Class 5</b>	<b>\$k, real 2023</b>
<b>Overheads</b>	<b>307,845</b>
Project Management, Coordination and Other Support	105,709
Property Acquisition, Environmental & Cultural Heritage	127,256
Environmental Offsets	74,880
<b>Transmission Lines</b>	<b>1,500,779</b>
Design	38,710
Procurement	129,405
Construction	1,330,832
Post Commissioning	1,832
<b>Substations</b>	<b>90,130</b>
Design	4,502
Procurement	45,192
Construction	33,671
Commissioning	6,667
Post Commissioning	99
<b>Telecoms</b>	<b>259</b>
<b>Network Operations</b>	<b>160</b>
<b>Estimate Total</b>	<b>1,899,174</b>
<b>Total Contingency</b>	<b>759,670</b>
Mitigated Risk (Known Risk)	379,835
Contingency (Unknown Risk)	379,835
<b>Estimate Total (including Risk &amp; Contingency)</b>	<b>2,658,844</b>

A detailed summary of the risks considered and included in each estimate are not available at this stage of development, therefore estimate allowances and risk costs have been based upon the class of estimate presented.



## Approvals and stakeholders

### Stakeholder engagement plan

Powerlink is committed to genuine and timely stakeholder engagement. A detailed stakeholder engagement plan will be developed prior to engagement activities commencing, which will apply the principles established in Powerlink's Engagement Framework [5]. Early engagement is anticipated with key stakeholders, including community members, landholders, Traditional Owners, our Customer Panel, State and Local Government representatives.

Engagement is expected to predominantly take the form of presentations and briefings, community briefings and one on one meetings. Powerlink will work with stakeholders to identify engagement preferences.

It is anticipated that constraints can be identified at an early stage and accommodated during the engagement phases of the corridor selection process with the final alignment aiming to avoid where possible. If avoidance cannot be accommodated, Powerlink will look to either reduce, mitigate or offset during the route finalisation process.

Consultation with the Traditional Owners is a significant component of the route selection process. Powerlink will engage and establish relationships with the relevant Traditional Owners and develop a Cultural Heritage Management Plan / Agreement in conjunction with the identified groups. This will also include a comprehensive on-site Cultural Heritage Survey conducted with the Traditional Owners. Measures will be implemented for the avoidance of impacts or management of Aboriginal Cultural Heritage.

Investigations into historical heritage will be conducted, and measures established to avoid impact on historic or other heritage.

### Relevant planning overlays

Detailed geospatial data and planning overlays are not available at this stage of development. This information will be made available as the corridor options become more firm following appropriate engagement with communities, landholders, Traditional Owners and relevant State and Local Government representatives.

### Estimate of planning approval complexity

Planning approval for the transmission line will be facilitated under the Ministerial Infrastructure Designation process, as per the Queensland Government's *Planning Act 2016*. No planning approval is required for the proposed substation works as the existing approval covers 330kV development at both Braemar and Bulli Creek and 500kV development at Halys. Impact on landholders is expected to be mainly along the existing corridor with very few, if any, additional properties affected by the easement. Overall the project has been assessed as having medium planning approval complexity, due to the number of stakeholders to be engaged, but risk of delays can be mitigated through early and effective engagement on the route selection.

## References

1. 2022 Integrated System Plan, June 2022, <https://aemo.com.au/-/media/files/major-publications/isp/2022/2022-documents/2022-integrated-system-plan-isp.pdf?la=en>, accessed 17 March 2023, Australian Energy Market Operator.
2. 2022 ISP Appendix 5. Network Investments, June 2022, <https://aemo.com.au/-/media/files/major-publications/isp/2022/2022-documents/a5-network-investments.pdf?la=en>, accessed 17 March 2023, Australian Energy Market Operator.
3. Queensland SuperGrid Infrastructure Blueprint, September 2022, [Queensland SuperGrid Infrastructure Blueprint \(epw.qld.gov.au\)](https://www.qld.gov.au/infrastructure/blueprint), accessed 17 March 2023, Queensland Government
4. Network Infrastructure Strategy for NSW, <https://www.energyco.nsw.gov.au/industry/network-infrastructure-strategy-nsw>, accessed 15 June 2023, EnergyCo.
5. Engagement Framework, <https://www.powerlink.com.au/engagement-framework>, accessed 17 March 2023, Powerlink Queensland.